



## MOUNTING ISTRUCTIONS

EN  
v1.0

Code: **AWO102**

Name: **Obudowa 7/25W/KS**

Metal enclosure for: alarms,....



**IM102**

Edition: 1 from 23.11.2022

### 1. Destination:

**AWO102** metal enclosure are designed as components (supplying) in intrusion alarm system, security KSENIA systems.

It is intended for installation:

- control panel board
- optional additional modules.

### 2. Installation:

Metal enclosure must be installed by a qualified installer, holding relevant certificates, with necessary permits and authorisations (required in installation country) to connect (interfere) with  $\sim 230$  V mains supply.

Because power supply is designed for continuous operation and is not equipped with ON/OFF switch, power supply circuit should have appropriate overload protection. Moreover, user shall be informed about method of unplugging (most frequently through separating and assigning an appropriate fuse in fuse-box). Electrical system shall follow valid standards and regulations. Enclosure shall follow mounted so as to ensure free, convection air flow through vents.

Enclosure should be installed indoor, where air humidity is normal (RH=90% max. without condensation) and temperature in range of  $-10^{\circ}\text{C}$  to  $+40^{\circ}\text{C}$ .



#### CAUTION!

Prior to entering for installation it is necessary to make sure if voltage in  $\sim 230$  V circuit is disconnected.

To switch power off, use an external switch, in which distance between contacts of all poles in disconnection state is not less than 3 mm.

**It is required to install in supply circuits, in addition to power supply, circuit breaker with 6 A nominal current.**

1. Mount (control panel, etc.) with dedicated holes (using pins, screws etc.).
2. Mount enclosure in a dedicated location, lead connection wires ( $\sim 230$  V) and signal cables through cable openings. Connect ground wire to terminal marked with grounding symbol  in enclosure. Use a three-core cable (with a yellow and green protection wire) to make connection.



**Shock protection circuit shall be done with a particular care: yellow and green wire coat of power cable should be connected to terminal marked with grounding symbol  on PSU enclosure. Operation of PSU without properly made and fully operational shock protection circuit is UNACCEPTABLE! It can cause damage to equipment or an electric shock.**

4. Connect power supply output to module power supply terminals, using installed cables.
5. If necessary, make other connections required for correct type of system/device.

**Notes:** consistent with requirements and recommendation of equipment producer.

6. **Start system (switch on  $\sim 230$  V, battery), adjust or configure: according to procedure of producer's system.**
7. After installing and checking proper operation of system, close enclosure.

### 3. Specifications:

---

**Table 1. Electrical parameters.**

<b>Supply voltage</b>	~ 100 – 240 V; 50/60 Hz
<b>Current consumption</b>	0,7 A
<b>Output power PSU</b>	25 W
<b>Efficiency</b>	83,5%
<b>Power supply output</b>	15 V DC / 1,7 A
<b>Ripple voltage</b>	120 mVp-p
<b>Adjustable output voltage</b>	13,5 – 16,5 V DC
<b>Overload protection OLP</b>	110 – 180% PSU power, automatically recovered
<b>Over voltage protection OVP</b>	17,25 – 20,25 V DC
<b>Tamper switch protection</b>	1 x microswitch: enclosure opening, 0,5 A; 50 V DC max. NC – normally closed contacts 1 x microswitch: detachment form wall, 0,5 A; 50 V DC max. NC – normally closed contacts
<b>Fuse in supply circuit 230 V</b>	T 2A/250
<b>Protection class EN 62368-1</b>	I (first)
<b>Declarations, warranty</b>	CE, 2 years from production date

**Table 2. Mechanical parameters.**

<b>External dimensions of enclosure</b>	W=250, H=292, D+D <sub>1</sub> =81+8 [+/-2 mm]
<b>External dimensions of front panel</b>	W <sub>1</sub> =256, H <sub>1</sub> =296 [+/-2 mm]
<b>Space for battery</b>	7 Ah / 12 V (SLA)
<b>Material</b>	Sheet steel DC01, thickness: 0,7 mm, protection anticorrosion, color: RAL 9003
<b>Closing</b>	sheet-metal screws x4
<b>Destination</b>	Inside
<b>Net/gross weight</b>	1.7 / 1.9 [kg]
<b>Notes</b>	Lock assembly possible MR008 / MR027, distance from wall (mounting surface) – 8mm

**Table 3. Operating parameters.**

<b>Protection grade EN60529</b>	IP20
<b>Operating temperature</b>	-10°C .. +40°C
<b>Storage temperature</b>	-20°C .. +60°C
<b>Relative humidity</b>	20%...90%, without condensation
<b>Sinusoidal vibrations during operation</b>	unacceptable
<b>Impulse waves during operation</b>	
<b>Direct insolation</b>	
<b>Vibrations and impulse waves during transport</b>	PN-83/T-42106

### 4. Panels which can be mounted in enclosure.

---

**KSENA:**

Alarm control panels: Lares 16, Lares 16 IP, Lares 4.0 – 16, Lares 4.0 wls 96 Kit.

Modules: Auxil, Auxil Relay, Auxil 10in, BUS Switch, PSTN, Gemino BUS, 3G.

---

*Documentation shows which devices can be installed in a given enclosure. It does not define how many different devices can be installed in one enclosure. Number of installed devices depends on their size and arrangement.*

---

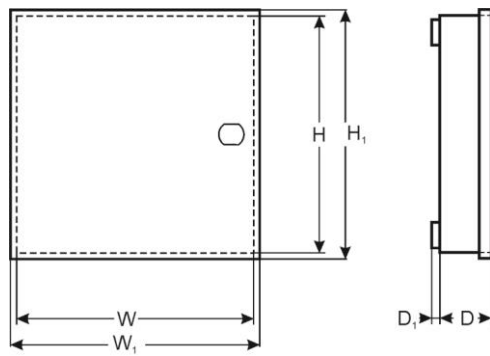
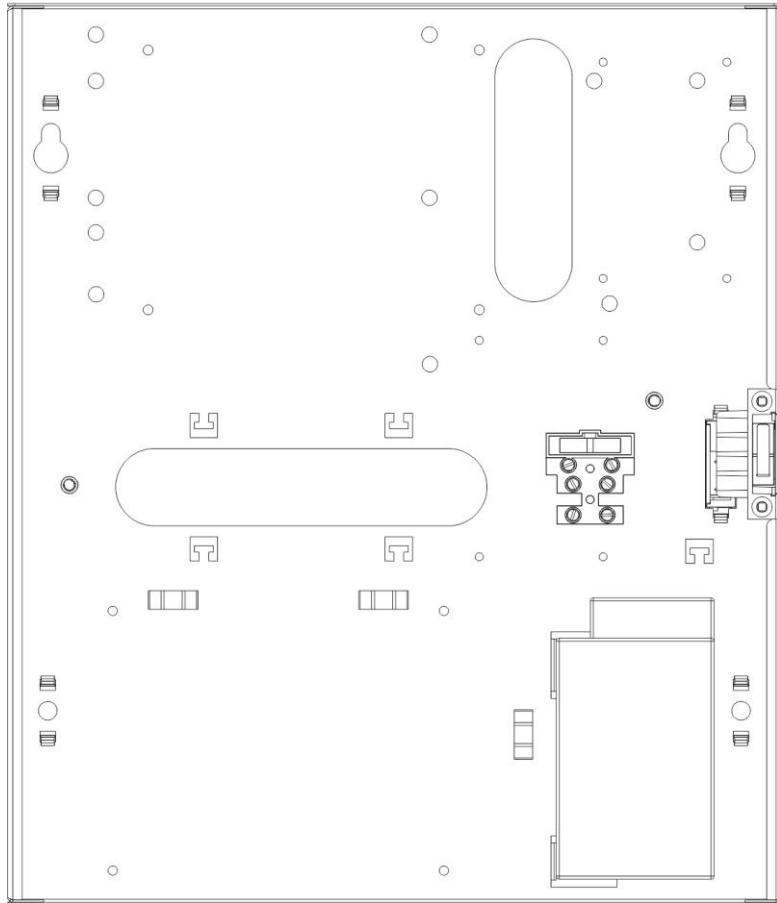

See Fig. 1.



**WEEE MARK**  
According to EU WEE Directive – It is required not to dispose of electric or electronic waste as unsorted municipal waste and to collect such WEEE separately.



*Device works with a lead-acid battery (SLA). After operation period it must not be disposed of but recycled according to applicable law.*

**Pulsar sp. j.**

Siedlec 150, 32-744 Łapczyca, Poland  
Tel. (+48) 14-610-19-40  
e-mail: [biuro@pulsar.pl](mailto:biuro@pulsar.pl), [sales@pulsar.pl](mailto:sales@pulsar.pl)  
http:// [www.pulsar.pl](http://www.pulsar.pl)