

The module's features:

- two control inputs of technical signals: IN1, IN2
- cooperation with power supply units of 12 and 24 V
- LED optical indication
- Protection against reverse connection of power supply
- Warranty – 5 years from production date

Technical description.

The AWZ639 relay module of technical outputs is designed to change the OC (open collector) outputs to relay outputs in buffer power supplies of 12 and 24 V. The LEDs on the PCB indicate the status of the individual relays. Power supply input of the module is protected against reverse connection of power supply. **CAUTION!** Module is intended for power supplies with technical outputs.

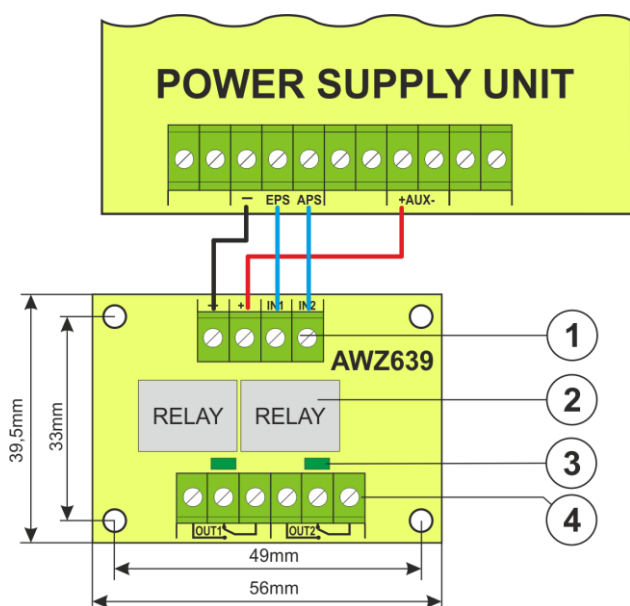

Fig.1. The scheme of the module.

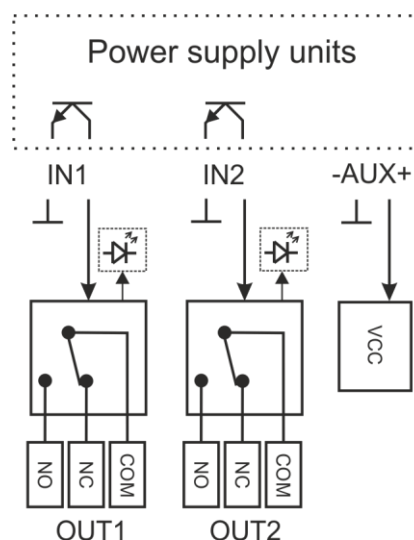

Fig. 2. Block diagram.

Table 1. The description of components and module connectors.

Component No. [Fig.1]	Description
①	Terminals: IN1, IN2 – control inputs of technical signals +, - – DC supply input
②	Relays
③	LEDs – indication of relay activation
④	OUT1, OUT2 – technical outputs, relay outputs.

Table 2. Technical parameters.

Supply voltage	10 V – 30 V DC
Current consumption	28 mA ÷ 45 mA @ U _{IN} = 10 V – 30 V DC
Technical outputs (relay type)	2 x 1 A @ 30 V DC / 48 V AC
Optical indication	Green LEDs - relay outputs status
Operating temperature	-10°C ÷ +40°C
Dimensions	L=69, W=43, H=20 [±/± 2mm]
Mounting	Mounting strip with adhesive tape
Connectors	Φ0,41 ÷ 1,63 (AWG 26-14)
Net/gross weight	0,03 / 0,05 [kg]

WEEE LABEL

Waste electrical and electronic equipment must not be disposed of with normal household waste. According to the European Union WEEE Directive, waste electrical and electronic equipment should be disposed of separately from normal household waste.

Pulsar sp. j.

Siedlec 150, 32-744 Łapczyca, Poland
Tel. (+48) 14-610-19-40, Fax. (+48) 14-610-19-50
e-mail: biuro@pulsar.pl, sales@pulsar.pl
http:// www.pulsar.pl, www.zasilacze.pl