

# Power supplies of following series

## RWB

v1.0

Switch mode power supply units with battery backup  
in RACK 19" 2U enclosure



**Features:**

- supply voltage ~200 – 240 V
- DC 52 (54) V uninterruptible power supply
- available versions with the following current efficiencies:  
**52 V: 2,3A**  
**54 V: 5A**
- high efficiency (up to 87%)
- battery charging current jumper selectable (only RWB-48V5A)
- deep discharge battery protection (UVP)
- possibility to mount ARAS...N rails
- **EPS** technical output for power failure - relay type
- LED optical indication
- battery output protection against short circuit and reverse connection
- protections:
  - SCP short circuit protection
  - OLP overload protection
  - OVP overvoltage protection
  - surge protection
- warranty: 2 years

**TABLE OF CONTENTS:**

1. Technical description.
  - 1.1. General description
  - 1.2. Block diagram
  - 1.3. Description of PSU components and connectors
  - 1.4. Specifications
2. Instalacja.
  - 2.1. Requirements
  - 2.2. Installation procedure
3. Operating status indication.
  - 3.1. Optical indication
  - 3.2. Technical outputs
  - 3.4. Battery charging time.
4. Integration of RACK Series Devices.
5. Maintenance.

**1. Technical description.**

**1.1. General description.**

Switch mode power supply units with battery backup RWB are intended for continuous power supply to devices that require stabilised voltage of 52 (54) V (e.g. PoE power systems, PoE switches). In case of lack of main power, battery back-up is activated immediately. The devices have been designed based on high-efficiency switch mode power supply modules mounted in metal enclosures (RAL 9005 colour – black) intended for installation in 19" RACK cabinets. The enclosures are equipped with a microswitch indicating opening of the cover. Moreover, the RWB-52V2A model features a built-in DC/DC converter, which reduces the construction and operating costs of a small system by limiting the number of batteries required.

**Parameters of power supplies:**

PSU's name	Output voltage	Charging current	Total output current with charging
RWB-52V2A	52 V	0,5 A	2,3 A
RWB-48V5A	54 V	0,5 / 1 / 2 A	5 A

1.2. Block diagram (Fig.1).

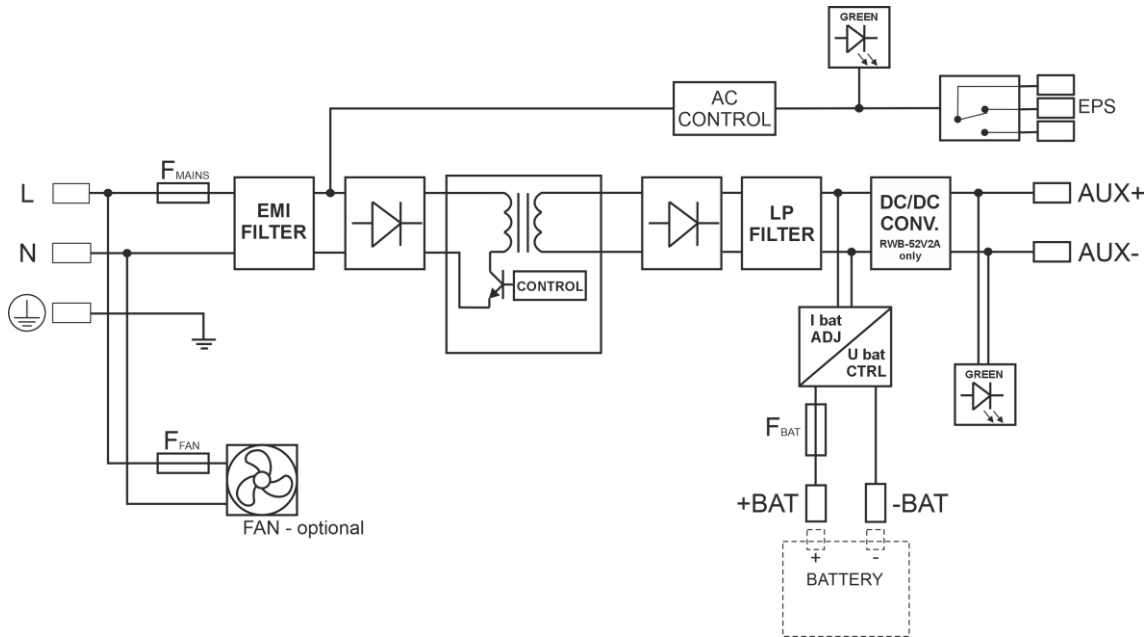













Fig.1. Block diagram of PSU.

1.3. Description of PSU components and connectors.

Table 1. Elements and connector of PSU (see Fig. 2a, 2b, 2c, 2d).

Element no.	Description
[1]	Output of PSU (- AUX +)
[2]	LED indicating the presence of AUX voltage
[3]	Battery connectors (- BAT +)
[4]	EPS – technical output of AC network absence indication
[5]	AC presence indication LED
[6]	Power supply connector ~230 V (IEC C14)
[7]	Selection jumper for charging current: Power supply: 12V10A; 24V5A: <ul style="list-style-type: none"> <li>• I<sub>BAT</sub> = , I<sub>BAT</sub> = I1</li> <li>• I<sub>BAT</sub> = , I<sub>BAT</sub> = I2</li> </ul> Power supply: 12V20A; 24V10A: <ul style="list-style-type: none"> <li>• I1 =  I2 =  I3 =  I<sub>BAT</sub> = I1</li> <li>• I1 =  I2 =  I3 =  I<sub>BAT</sub> = I2</li> <li>• I1 =  I2 =  I3 =  I<sub>BAT</sub> = I3</li> </ul>
[8]	Battery fuse
[9]	Fan (only models >200 W)

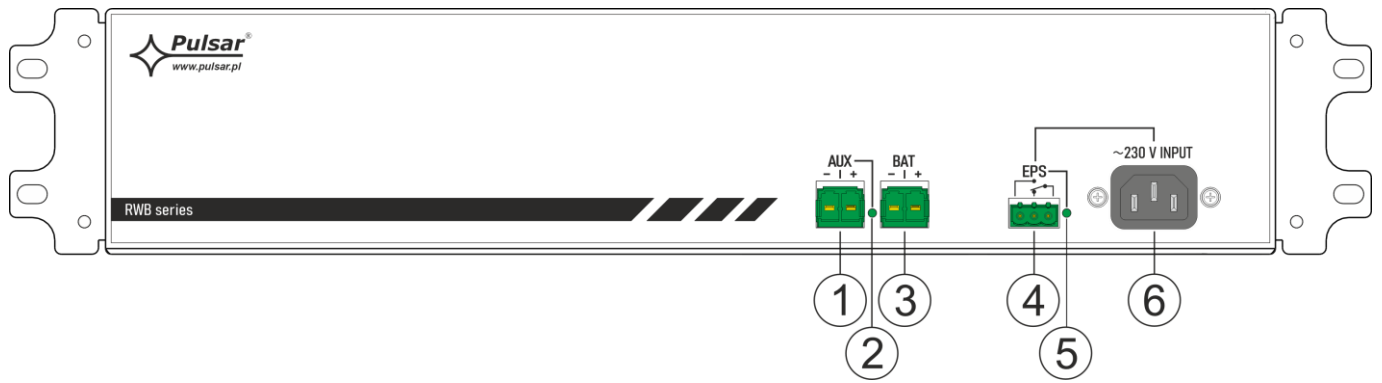

Fig. 2a. Front panel view

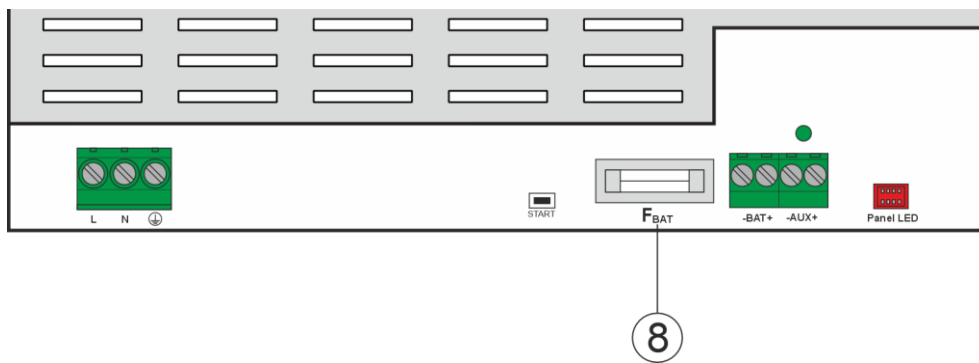

Fig. 2b. View of power supply module (52V2A models)

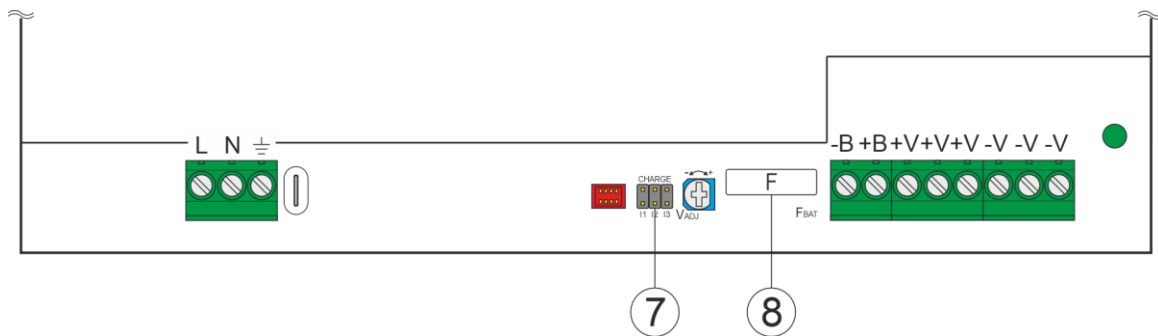

Fig. 2c. View of power supply module (48V5A models)

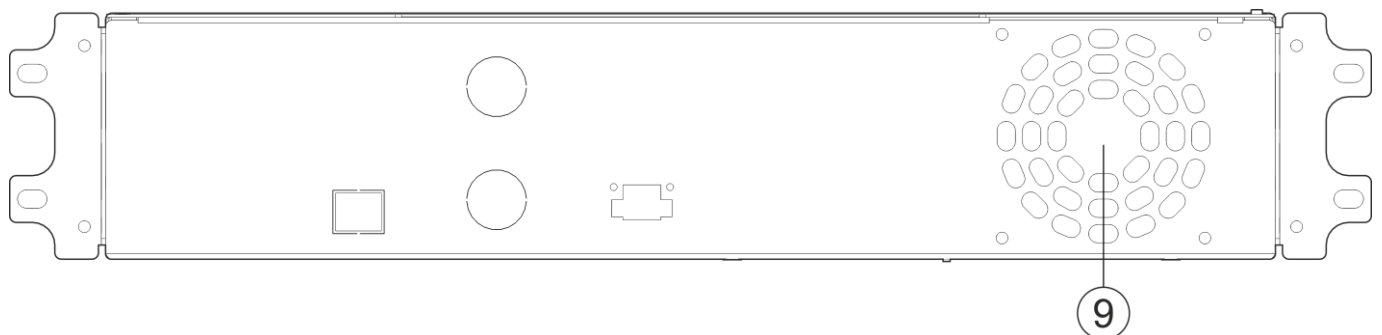

Fig. 2d. Rear panel view

**1.4. Specifications:**

- electrical parameters (Tab. 3)
- operation safety (Tab. 4)
- operating parameters (Tab. 5)

**Table 3. Electrical parameters.**

Model	RWB-52V2A	RWB-48V5A
Supply voltage	~ 200 – 240 V	
Current consumption	1,2 A	1,5 A
Power frequency	50/60 Hz	
Inrush current	60 A	
Output power PSU	134 W	270 W
Total output current with charging	2,3 A	5 A
Efficiency	87%	87%
Output voltage	52 V - buffer operation 52 V - battery-assisted operation	44 – 54 V - buffer operation 38 – 54 V - battery-assisted operation
Ripple voltage (max.)	100 mV p-p	150 mV p-p
Current consumption by PSU systems during battery-assisted operation	50 mA	40 mA
Battery capacity (recommended)	7 – 20 Ah	7 – 65Ah
Number of batteries	2	4
Charging voltage	22 – 27,6 V	44 – 54 V
Charging current (jumper selectable)	I1: 0,5 A	I1: 0,5 A I2: 1 A I3: 2 A
Net/gross weight	4,4 / 4,8 [kg]	4,9 / 5,4 [kg]
Battery circuit protection SCP and reverse polarity connection	- F <sub>BAT</sub> fuse (in case of a failure, fuse-element replacement required)	
Overload protection (OLP)	105 – 150% of power supply, automatic recovery	
Over voltage protection (OVP)	>37 V (after running, disconnect PSU for about 1 minute)	>60 V (after running, disconnect PSU for about 1 minute)
Deep discharge battery protection UVP	U<19 V (± 5%) - disconnection of battery circuit	U<38 V (± 5%) - disconnection of battery circuit
Optical indication	- LEDs on the front panel	
Technical outputs: -EPS (AC power failure)	relay type: 1A@ 30 V DC / 50 V AC	
Fuse: - F <sub>BAT</sub>	F 5A/250V	T 5A
Enclosure dimensions (LxWxH) [±2mm]	W=19", H=2U; 481 x 88 x 274 (WxHxD)	
Enclosure colour:	RAL 9005 (black)	
Terminals: Mains supply: Outputs: Technical outputs:	IEC C14 power inlet Φ0,5÷3,2 (AWG 24-8) 0,5-4mm <sup>2</sup> Φ0,5-2,1 (AWG 24-12) 0,5-1,5mm <sup>2</sup>	
Equipment:	1.8 m power cable, set of connectors (2x PC 5/2-2P, 2x 2EDGK-3P)	
Notes:	Convictional cooling	Forced cooling

**Table 4. Operation safety.**

Protection class EN 62368-1	I (first)
Degree of Protection EN 60529	IP20
Electrical strength of insulation: - between the input (mains) circuit and the power supply output circuits - between input circuit and protection circuit - between output circuit and protection circuit	4000 V DC min. 2500 V DC min. 500 V DC min.
Isolation resistance: - between input circuit and output or protection circuit	100 MΩ, 500 V DC

**Table 5. Operating parameters.**

Operating temperature	-10°C...+40°C
Storage temperature	-20°C...+60°C
Relative humidity	20%...90%, without condensation
Vibrations during operation	unacceptable
Impulse waves during operation	unacceptable
Direct insolation	unacceptable
Vibrations and impulse waves during transport	According to PN-83/T-42106

## 2. Installation.

### 2.1 Requirements.

Buffer power supply is designed to be installed only by qualified installer with necessary permits and authorisations (required in installation country) to connect (interfere) with the 230 V mains supply. The device should be installed in a metal enclosure (cabinet) in a horizontal position to ensure free airflow through the ventilation openings. In order to meet the EU requirements, follow the guidelines on: power supply, enclosures and shielding: - according to application.

As power supply is designed for a continuous operation and is not equipped with a power-switch, therefore, an appropriate overload protection in power supply circuit should be provided. Moreover, the user shall be informed about the method of unplugging (most frequently through separating and assigning an appropriate fuse in the fuse-box). The electrical system shall follow valid standards and regulations.

### 2.2 Installation procedure.



#### CAUTION!

**Before installation, cut off voltage in 230 V power-supply circuit. To switch power off, use an external switch, in which distance between contacts of all poles in disconnection state is not less than 3mm.**

**It is required to install in the supply circuits, in addition to power supply, circuit breaker with 6 A nominal current.**

1. Mount the PSU in a selected location and connect the wires.
2. Connect the ~230 V AC power cable with IEC C13 plug (included) to the ~230 V input socket of the power supply.



**The device is designed to protection class I, therefore it must be connected only to an installation with an effective shock protection (earthing) circuit. Operation of the PSU without the properly made and fully operational shock protection circuit is UNACCEPTABLE! It can cause a device failure or an electric shock.**

3. If necessary, connect device cables to the technical output (using the included 2EDGK-2P connectors):  
- EPS; technical output of AC network absence indication
4. Connect the load(s) to the AUX output connector using the included PC5/2-2P plug. Maintain correct polarity (positive pole marked "+", negative pole marked "-").
5. Use the I<sub>BAT</sub> jumper to set the maximum battery charging current, taking into account charging capacity and required charging time.
6. Connect the battery/batteries to the BAT output connector using the included PC5/2-2P plug. Maintain correct polarity (positive pole marked "+", negative pole marked "-") and appropriate connection configuration (Fig. 4):

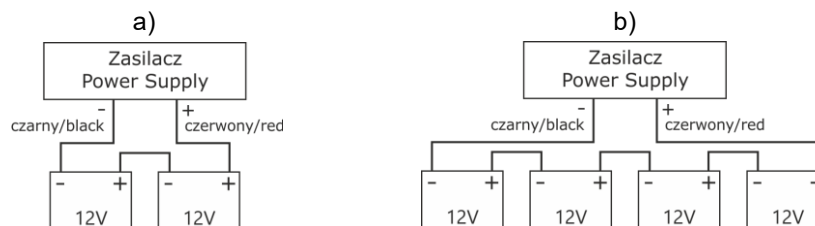

Fig. 4 Connecting batteries depending on voltage version of power supply:  
a) RWB-52V2A, b) RWB-48V5A,

7. Switch on 230 V supply. The LEDs indicating the presence of AUX voltage and ~230 V on the front panel should light up.
8. After installing and checking proper working, the enclosure can be closed.

**Output voltage of the PSU, without load  $U = 52 (54) \text{ V DC}$ .**

**During battery charge, voltage can amount to  $U = 52 \text{ V DC (RWB-52V2A)}$ ;  $44 - 54 \text{ V DC (RWB-48V5A)}$**

9. Perform power supply tests: check optical indication (Table 7), technical outputs by:
  - **cutting off the 230 V current:** the AC LED (Fig. 2, item 5) will turn off, and the EPS technical output will change its state after approximately 30 s.

### 3. Operating status indication.

#### 3.1 Optical indication.

The power supply is equipped with optical status indication located on the front panel.

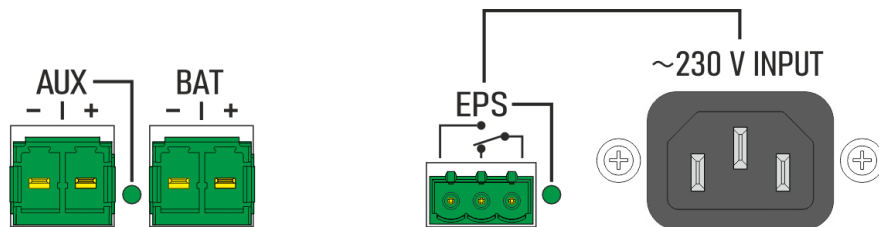

#### Green EPS LED:

- ON - the PSU is supplied with 230 V
- OFF - no 230 V power, battery-assisted operation

#### Green AUX LED:

- ON - presence voltage in output of PSU

#### 3.2 Technical outputs.

The PSU is equipped with indication outputs:

- **EPS - output indicating 230 V power loss.**  
The output indicates 230 V power failure. In case of power failure, contacts of relay change over after about 30 seconds.

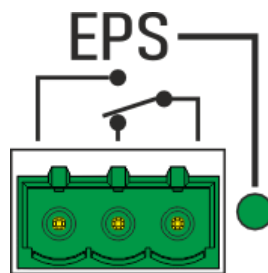

**CAUTION!** The figure set of contacts shows a potential-free status of relay, which corresponds to power supply failure.

#### 3.3 Battery charging time.

The PSU has a battery circuit charged with direct current. The current selection is done with use of the  $I_{BAT}$  jumpers\*. The table below shows how long does it take to charge a (fully discharged) battery up to min. 80% of its nominal capacity.

Table 6. Approximate battery charging time up to the capacity of 0,8.

Battery	Charging current		
	0,5 A	1 A*	2 A*
7Ah	14h	7h	-
17Ah	32h	16h	8h
28Ah	-	26h	13h
40Ah	-	36h	18h
65Ah	-	-	30h

\* only for RWB-48V5A model

#### 4. Integration of RACK Series Devices.

RWB series buffer power supplies are part of the Pulsar RACK system, which includes: the RDS fuse module, the RackPack battery enclosure, and RSG2 series power supplies. The devices are visually matched and feature a standardized connection method, which simplifies installation and allows the system to be adapted to individual requirements. An example configuration is shown below:

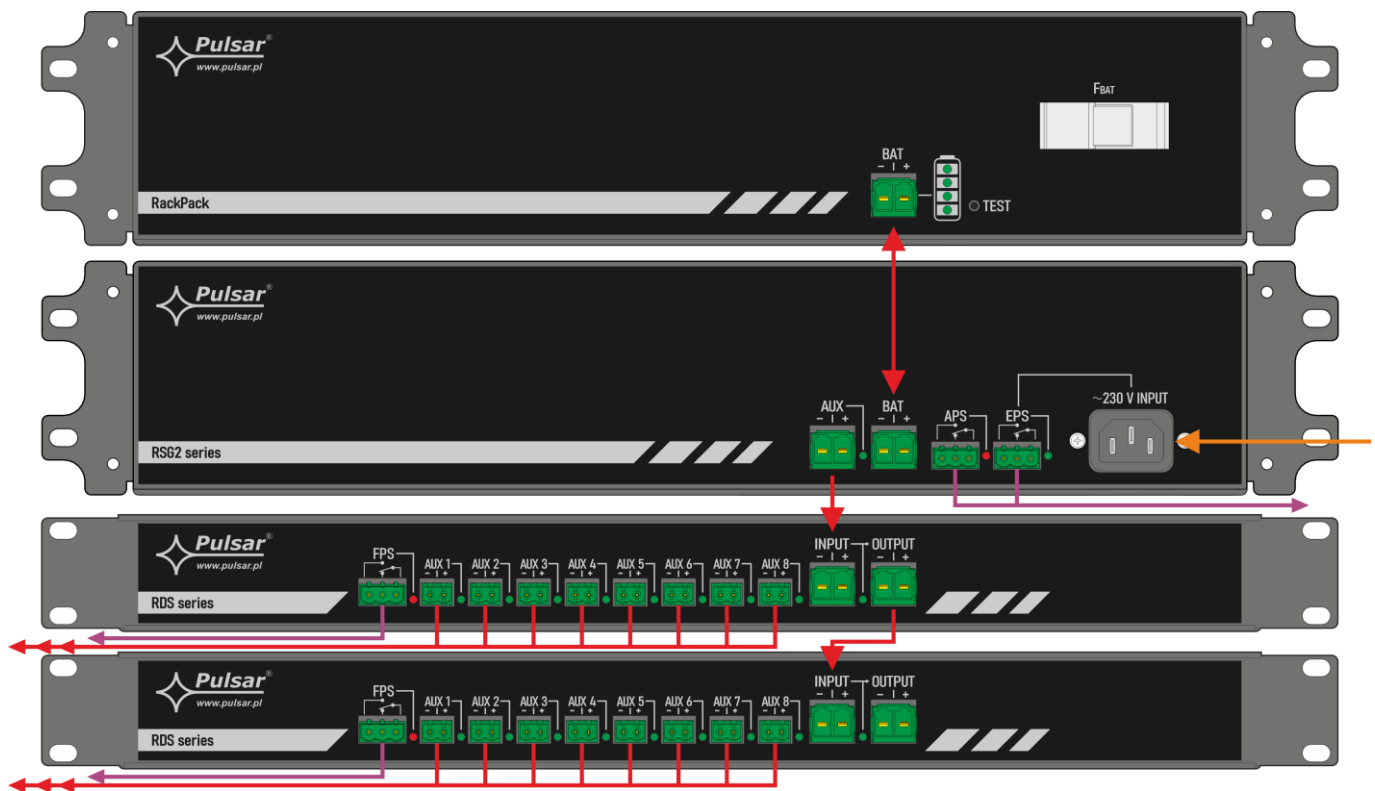

#### 5. Maintenance.

The figure set of contacts shows a potential-free status of relay, which corresponds to power supply failure. PSU does not require any specific maintenance, however, its interior should be cleaned with compressed air if it is used in dusty conditions. In case of fuse replacement, use only compatible replacement parts.



**WEEE LABEL**

**Waste electrical and electronic equipment must not be disposed of with normal household waste. According to European Union WEEE Directive, waste electrical and electronic equipment should be disposed of separately from normal household waste.**



**Pulsar sp. j.**

Siedlec 150,  
32-744 Łączycza, Poland  
Tel. (+48) 14-610-19-45  
e-mail: [sales@pulsar.pl](mailto:sales@pulsar.pl)  
http:// [www.pulsar.pl](http://www.pulsar.pl)

