

Features:

- Switch 16 ports
- 16 PoE ports 10/100 Mb/s (data transfer and power supply)
- 2 ports 10/100/1000 Mb/s (G1/TP, G2/TP ports) (UpLink)
- 2 ports 1000 Mb/s SFP (G1/SFP, G2/SFP ports) (UpLink)
- 30 W for each PoE port, supports devices compliant with IEEE802.3af/at (**PoE+**) standard
- Supports auto-learning and auto-aging of MAC addresses (16K size)
- LED indication
- Additional assembly elements
- warranty – 2 years from production date

Example of use.

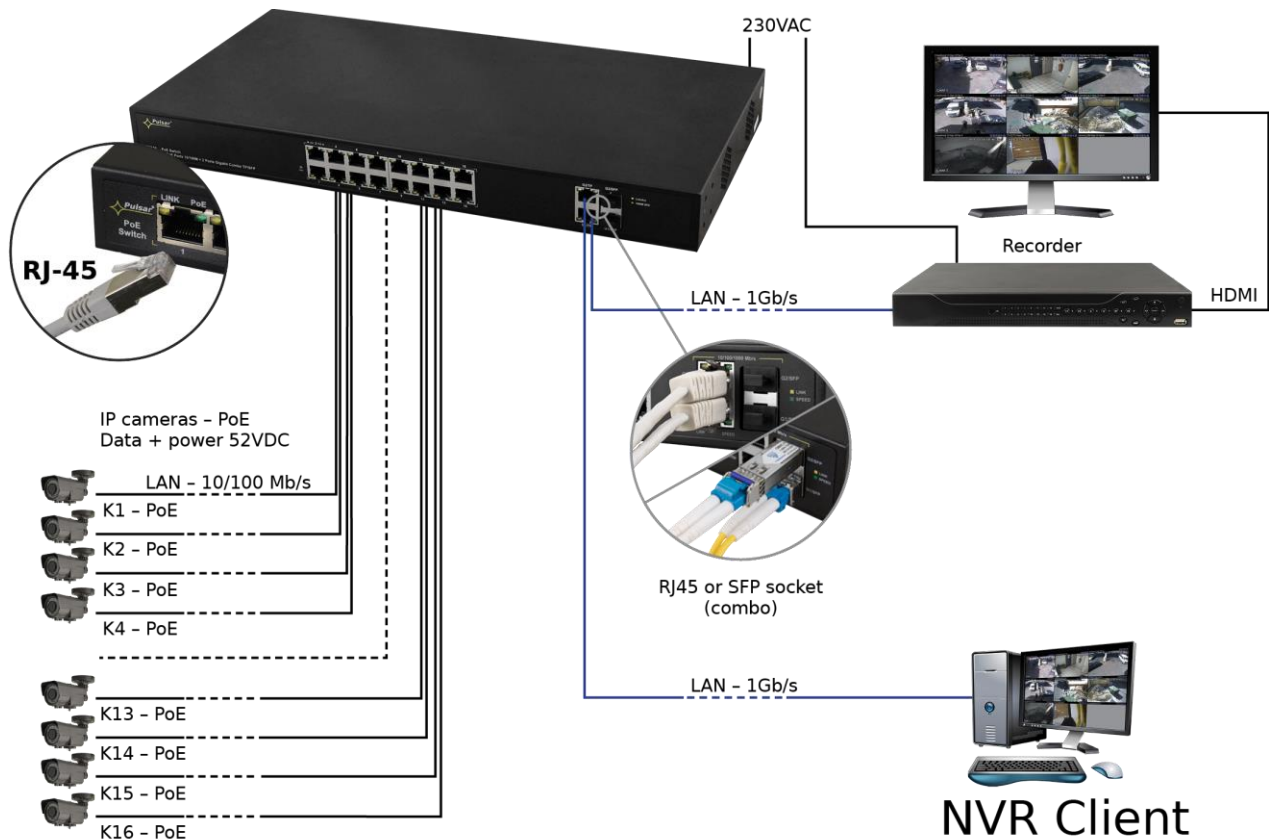

1. Technical description.

1.1. General description.

SF116 is a 16-ports PoE switch designed to supply IP cameras operating in IEEE 802.3af/at standard. Automatic detection of any devices powered in the PoE/PoE+ standard is enabled at the 1 – 8 ports of the switch. The G1/TP and G2/TP ports is used for connection of another network device via RJ45 connector. The switch is fitted with SFP slots (marked as G1/SFP and G2/SFP), the use of fiber optic module (GBIC) allows fiber optic transmission. The operating status of the device (described in the table below) is displayed on the LED display on the front panel.

The PoE technology ensures a network connection and reduces installation costs by eliminating the need to supply a separate power cable for each device. This method allows supplying other network devices, such as IP phone, wireless access point or router.

1.2. Block diagram.

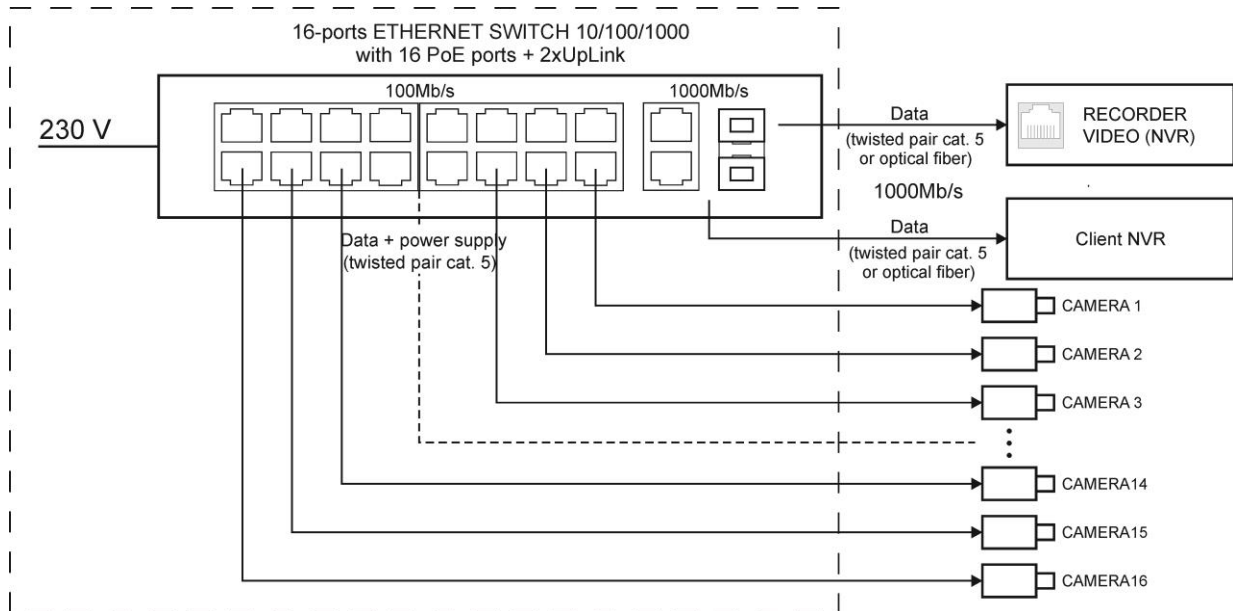

Fig. 1. Block diagram.

1.3. Description of components and connectors.

Table 1. (see Fig. 2, 3 and 4)

Element no. (Fig. 2)	Description
[1]	LED indication
[2]	16 x PoE port (1÷16)
[3]	2 x UPLINK ports (G1/TP, G2/TP)
[4]	2 x UPLINK ports (G1/SFP, G2/SFP)
[5]	Power Socket of the 230 V
[6]	Additional mounting elements

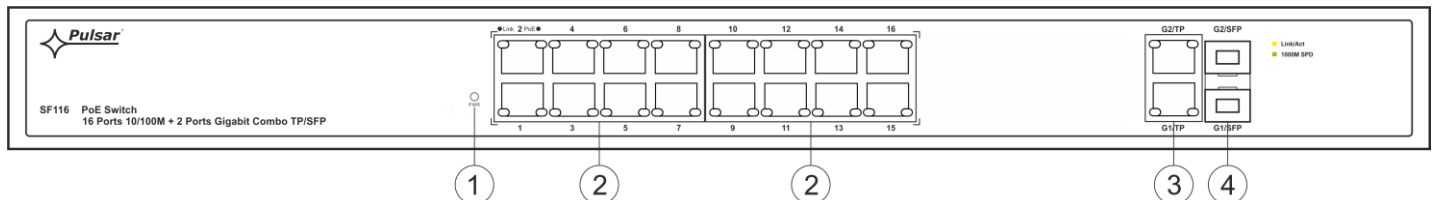

Fig. 2. The front power of the switch.

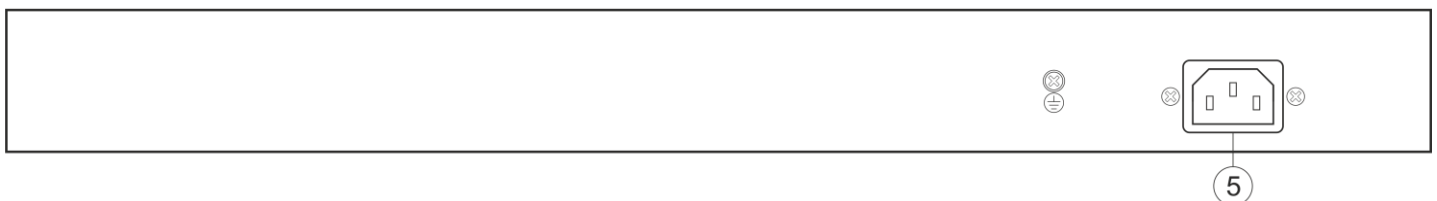

Fig. 3. Rear panel of the switch.

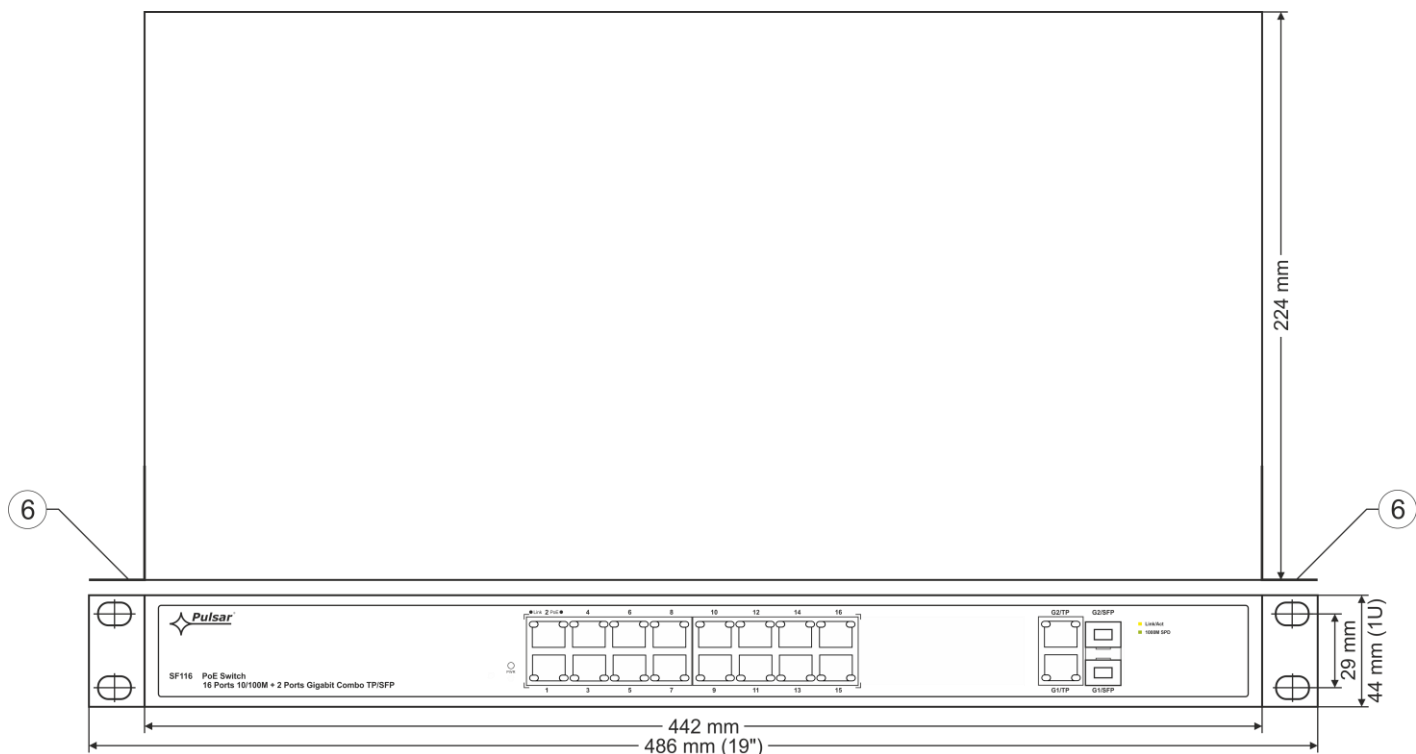

Fig. 4. The view switch'a.

1.4. Technical parameters

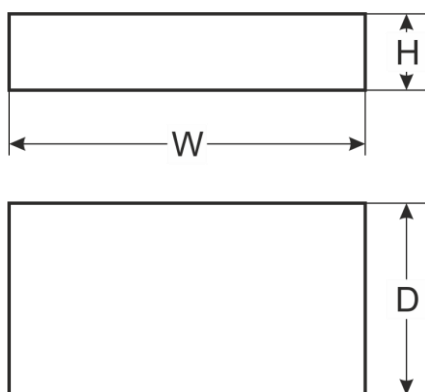

Table 2.

Ports	16 x PoE (10/100 Mb/s) (RJ-45) 2 x UpLink (10/100/1000 Mb/s) (RJ-45) 2 x UpLink (1000 Mb/s) (SFP) with connection speed auto-negotiation and MDI/MDIX Auto Cross
PoE power supply	IEEE 802.3af/at (1÷16 ports), 52 V DC / 30 W at each port * Used pairs 1/2 (+), 3/6 (-)
Protocols, Standards	IEEE802.3, 802.3u, 802.3x CSMA/CD, TCP/IP
Bandwidth	14,8 Gb/s
Transmission method	Store-and-Forward
Optical indication of operation	Switch power supply Link PoE Status
Power supply	~100-240 V; 50/60 Hz; 3 A
Operating conditions	Temperature: -10°C ÷ +40°C relative humidity 20%...90%, without condensation
Dimensions	W=442, H=44, D=224 [+/- 2mm]
Additional equipment	bracket for RACK 19"
Cable length AC	1,2m
Net/gross weight	2,7 / 3,1 [kg]
Protection class EN 62368-1	I (first)
Storage temperatur	-20°C ÷ +60°C
Declarations	CE

* The given value of 30 W per port is the maximum value. The total power consumption should not exceed 160 W.

2. Installation.

2.1. Requirements.

Unit should be mounted in confined spaces with normal relative humidity (RH=90% maximum, without condensing) and temperature from -10°C to +40°C. Ensure the free flow of air around the unit. The PSU shall work in a vertical position that guarantees sufficient convectional air-flow through ventilating holes of the enclosure.

The switch load balance should be done before installation. The given value of 30 W per port is the maximum value referring to a single output. The total power consumption should not exceed 160 W. The increased demand for power is particularly evident in the case of cameras with heaters or infrared illuminators - when launching these features, the power consumption increases rapidly, which may adversely affect the operation of the switch. As the device is designed for a continuous operation and is not equipped with a power-switch, therefore an appropriate overload protection in the power supply circuit should be provided. The electrical system shall be made in accordance with applicable standards and regulations.

2.2. Installation procedure.

1. Connect the 230 V power supply and turn on the device. The connection should be made with the supplied 3-core cable with a plug. The place and method of installation of the switch should ensure free air flow around the unit.
2. Connect the camera wires to the RJ45 connectors (sockets RJ45 from 1 to 16).
3. Connect the remaining LAN devices to RJ45 connectors or SFP socket (G1/TP and G1/SFP or G2/TP and G2/SFP)
CAUTION! G1/TP and G1/SFP or G2/TP and G2/SFP connectors can not operate simultaneously!
4. Check the optical indication of switch operation (see Table 3).

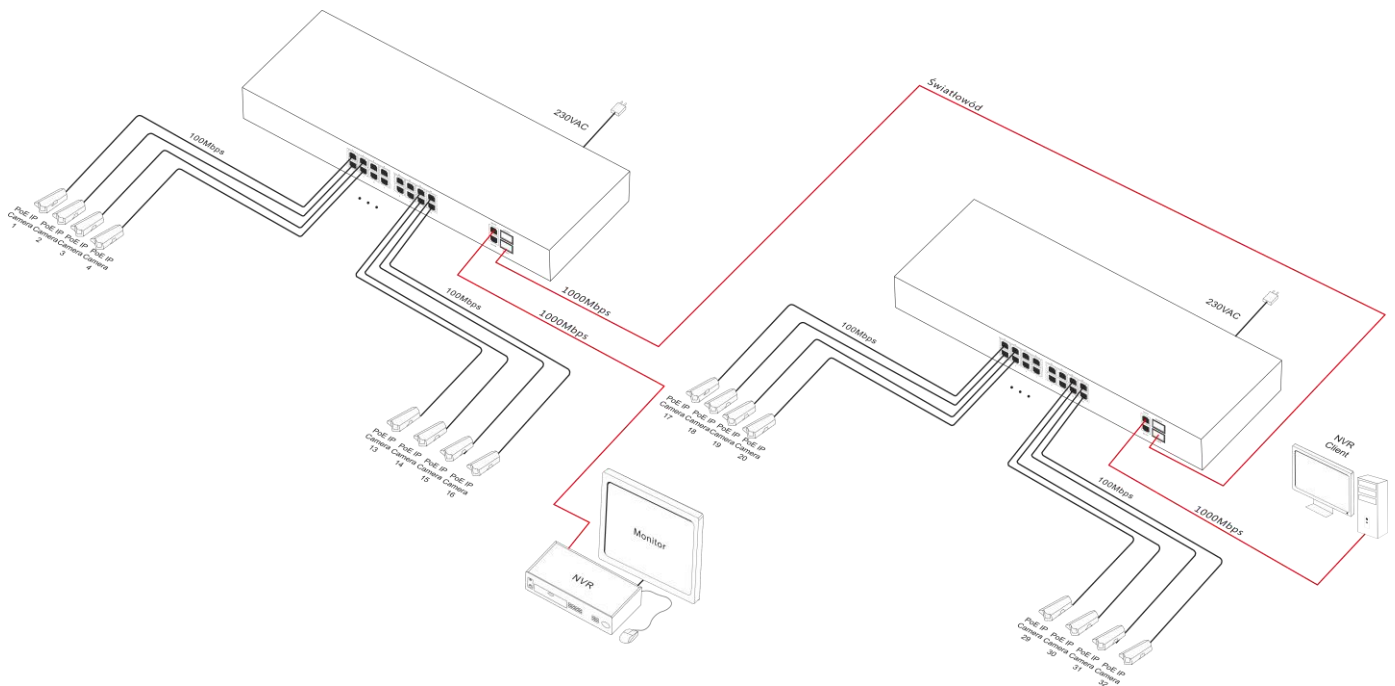

Connection schemes:





3. Operation indication (see table 3)

Table 3. Operation indication

OPTICAL INDICATION OF THE SWITCH'S POWER SUPPLY		
YELLOW LED LIGHT (Power) Indication of the switch's power supply	PWR 	OFF – no power supply of the switch ON – power supply on, normal operation

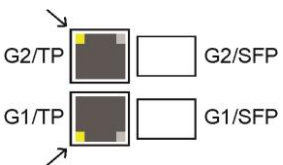
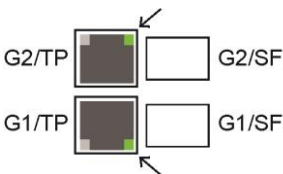
OPTICAL INDICATION AT THE PoE PORTS (1÷16)		
GREEN LED LIGHT (PoE) Indication of the PoE power supply at the RJ45 ports		OFF – no power supply at the RJ45 port (the device is not connected or not compliant with the IEEE802.3af standard) ON – supply Blinking – short-circuit or output overload
YELLOW LED LIGHT (LINK) The connection status of LAN devices, 10 MB/s or 100 Mb/s and data transmission		OFF – no connection ON – the device is connected; 10 Mb/s or 100 Mb/s Blinking – data transmission

OPTICAL INDICATION AT THE UPLINK PORT (G1/TP, G2/TP, G1/SFP, G2/SFP)		
YELLOW LED LIGHT (LINK)		OFF – no connection ON – the device is connected Blinking – data transmission CAUTION! The operating status of the G1/TP, G1/SFP, G2/TP and G2/SFP slots is shown on the LEDs located near the RJ45 connector (see below). CAUTION! G1/TP and G1/SFP or G2/TP and G2/SFP sockets can not operate simultaneously. These are COMBO type sockets.
GREEN LED LIGHT (SPEED)		OFF – connection 10 Mb/s or 100 Mb/s ON – connection 1000 Mb/s CAUTION! The operating status of the G1/TP, G1/SFP, G2/TP and G2/SFP slots is shown on the LEDs located near the RJ45 connector (see below). CAUTION! G1/TP and G1/SFP or G2/TP and G2/SFP sockets can not operate simultaneously. These are COMBO type sockets.



WEEE LABEL

Waste electrical and electronic equipment must not be disposed of with normal household waste. According to the European Union WEEE Directive, waste electrical and electronic equipment should be disposed of separately from normal household waste.

Pulsar sp. j.
 Siedlec 150, 32-744 Łapczyca, Poland
 Tel. (+48) 14-610-19-45
 e-mail: sales@pulsar.pl
 http:// www.pulsar.pl

