

Features:

- Switch 12 ports
- 8 PoE ports 10/100/1000 Mb/s, (1÷8 port) (data transfer and power supply)
- 2 ports 10/100/1000 Mb/s (TP/9, TP/10 ports) (UpLink)
- 2 ports 1000 Mb/s SFP (SFP/11, SFP/12 ports)
- 30W for each PoE port, supports devices compliant with IEEE802.3af/at standard
- Supports auto-learning and auto-aging of MAC addresses (4K size)
- Optical indication
- The PSD 520175 power supply desktop type 52 V DC; 1,75 A /90 W max. included
- Additional mounting elements
- Warranty – 2 years

Example of use.

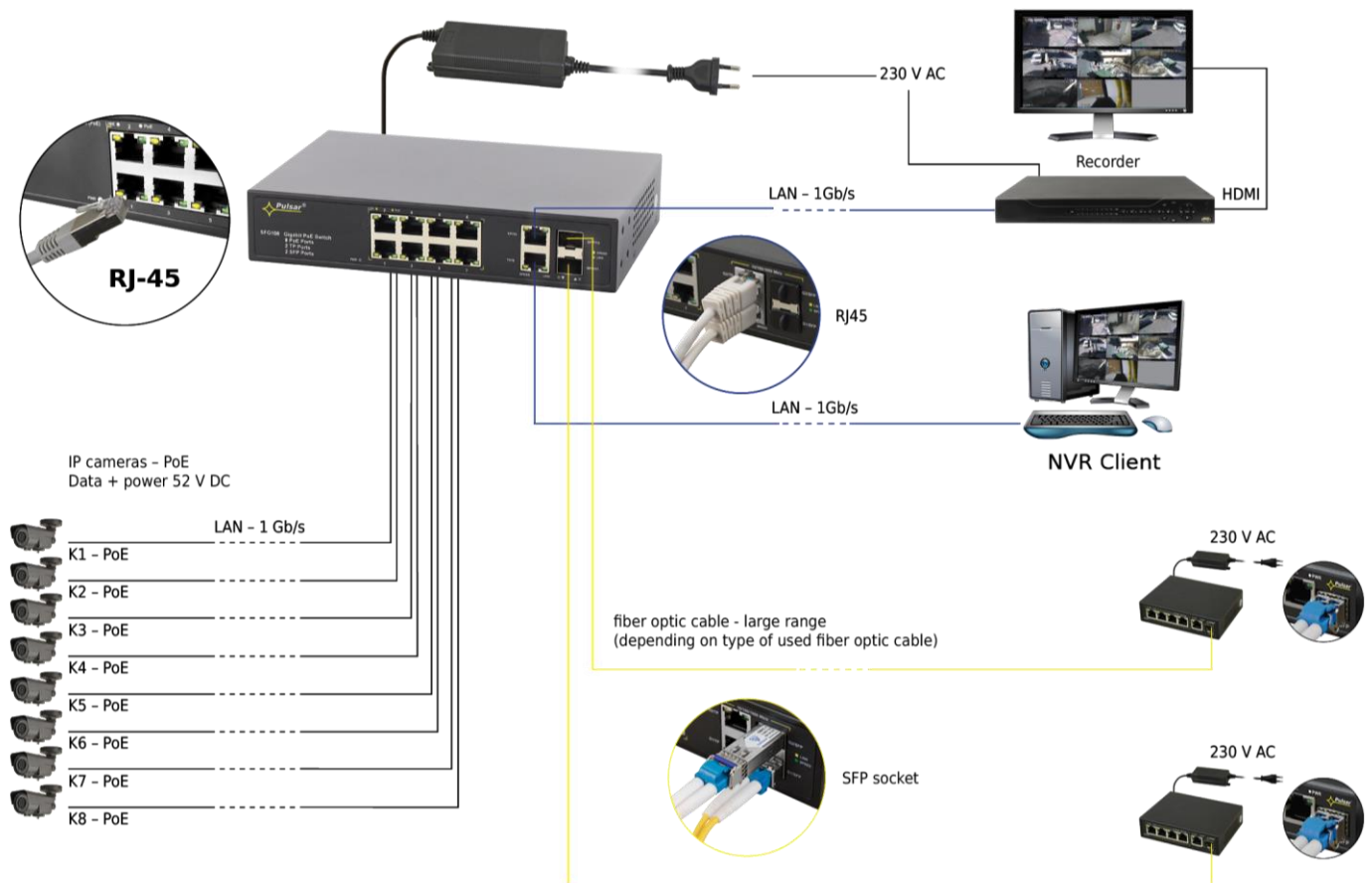

1. Technical description.

1.1. General description.

SFG108-90W is a 12-ports PoE switch designed to supply IP devices operating in IEEE 802.3af/at standard. The switch - at ports 1-8 - automatically detects devices powered in the PoE standard. Ports marked TP/9 and TP/10 allow connecting additional network devices via RJ45 connectors. The switch is also equipped with two SFP sockets (labeled SFP/11 and SFP/12), They allow data transmission via optical fiber using a fiber optic module (SFP GBIC).

On front panel there is LEDs signaling of the device's status (description in table 3). The PoE technology provides a network connection and reduces installation costs by eliminating the need to supply a separate power cable to each device. In addition to cameras, other network devices using this technology can be supplied in this way, e.g. IP phone, wireless access point, router.

1.2. Block diagram.

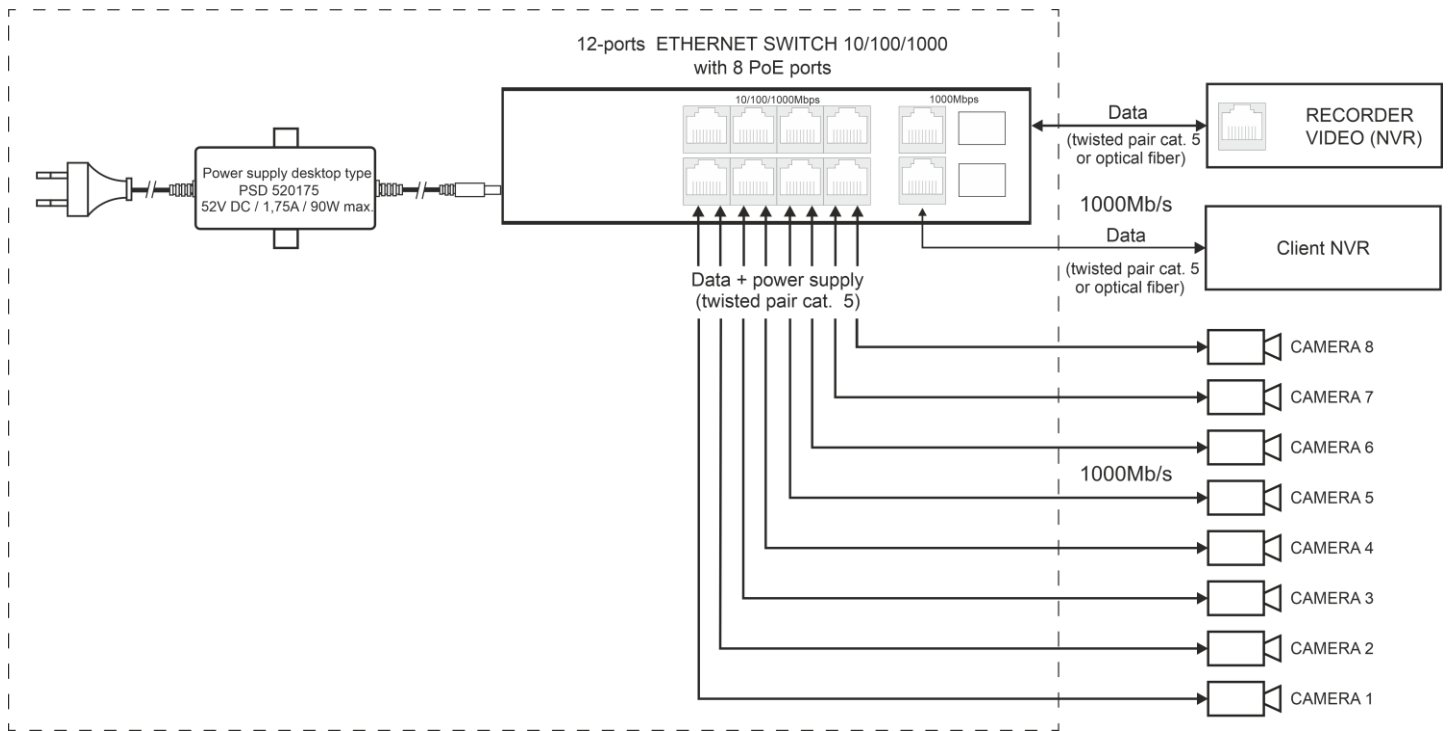

Fig. 1. Block diagram.

1.3. Description of components and connectors

Table 1. (see Fig. 2)

Element no. (Fig. 2)	Description
[1]	8 x PoE port (1÷8)
[2]	2 x UPLINK port (TP/9, TP/10)
[3]	2 x UPLINK port (SFP/11, SFP/12)
[4]	52 V DC power socket
[5]	Additional mounting elements

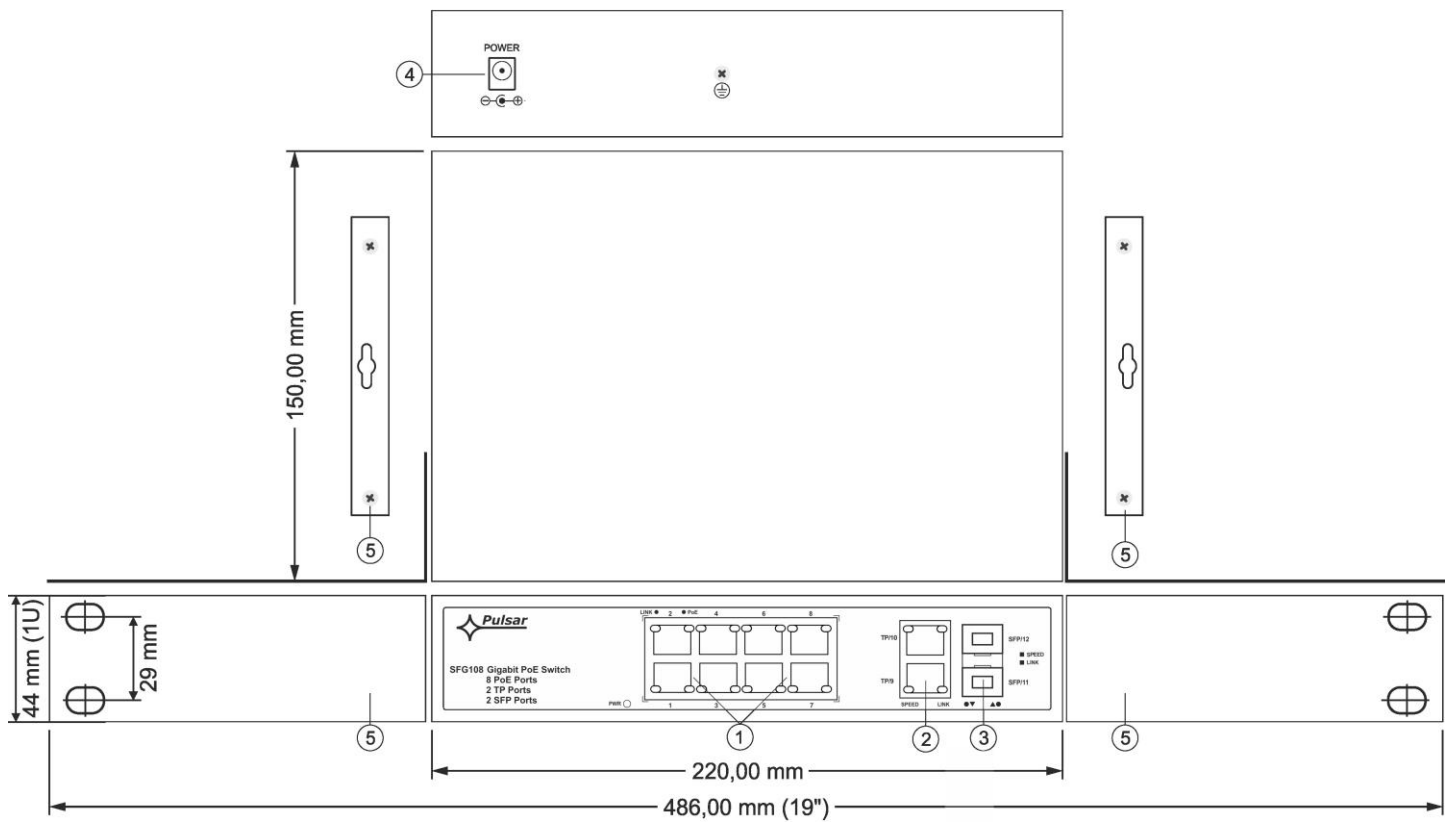

Fig. 2. View of the switch.

1.4. Specifications (Table 2.)

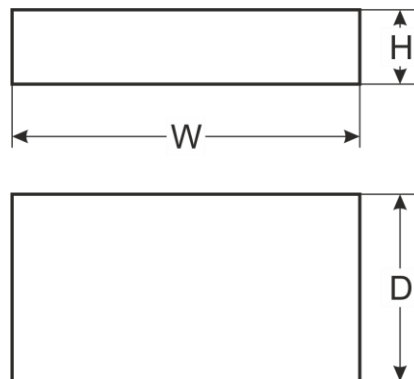

Table 2.

Ports	8 x PoE (10/100/1000 Mb/s) (RJ-45) 2 x UPLINK (10/100/1000 Mb/s) (RJ-45) 2 x UPLINK (1000 Mb/s) (SFP) with auto negotiation of connection speed, auto MDI/MDIX crossover
PoE supply	IEEE 802.3af/at (1+8 ports), 52 V DC / 30 W at each port *
Protocols, Standards	IEEE802.3, 802.3u, 802.3x, 802.3ab, 802.3z, TCP/IP
Bandwidth	24 Gb/s
Transmission method	Store-and-Forward
Optical indication of operation	Switch supplying Link PoE Status
Power supply	~100-240 V; 50/60 Hz; 1 A The PSD 520175 power supply desktop type 52 V DC; 1,75 A /90 W max.
Operating conditions	Temperature: -10°C ÷ +40°C, relative humidity 20%...90%, without condensation
Dimensions	W=220, H=44, D=150 [+/- 2 mm]
Additional accessories	Surface mounting sheets, mount brackets ing for RACK 19"
Net/gross weight	1,4 / 1,6 [kg]
Protection class	I (first)
EN 62368-1	
Storage temperature	-20°C ÷ +60°C
Declaration	CE

* The given value of 30 W per port is the maximum value. The total power consumption should not exceed 80 W.

2. Installation

2.1. Requirements

Unit should be mounted in confined spaces with normal relative humidity (RH=90% maximum, without condensing) and temperature from -10°C do +40°C. Ensure the free flow of air around the unit. The device shall work in a vertical position that guarantees sufficient convectional air-flow through ventilating holes of the enclosure.

The load balance should be done before installation Switcha. The given value of 30 W per port is the maximum value referring to a single output. The total power consumption should not exceed 80 W. The increased demand for power is especially visible when cameras are equipped with heaters or infrared illuminators. When these elements are turned on, power consumption increases rapidly, which may result in incorrect operation of the switch. Device is designed for continuous operation, it does not have a power switch. Therefore, the power supply circuit should be provided with appropriate overload protection. The electrical system shall follow valid standards and regulations.

2.2. Installation procedure

1. Connect the switch to the power supply type PSD520175 52 V DC.
2. Connect the power supply to the 230 V socket.
3. Connect the camera cables to the RJ45 (PoE connectors (RJ45 sockets 1 to 8)).
4. Connect the remaining LAN devices to RJ45 connectors (TP/9 and TP/10) and SFP sockets (SFP/11 and SFP/12)
5. Check the switch operation indicator (see Table 3).

Examples of connection:

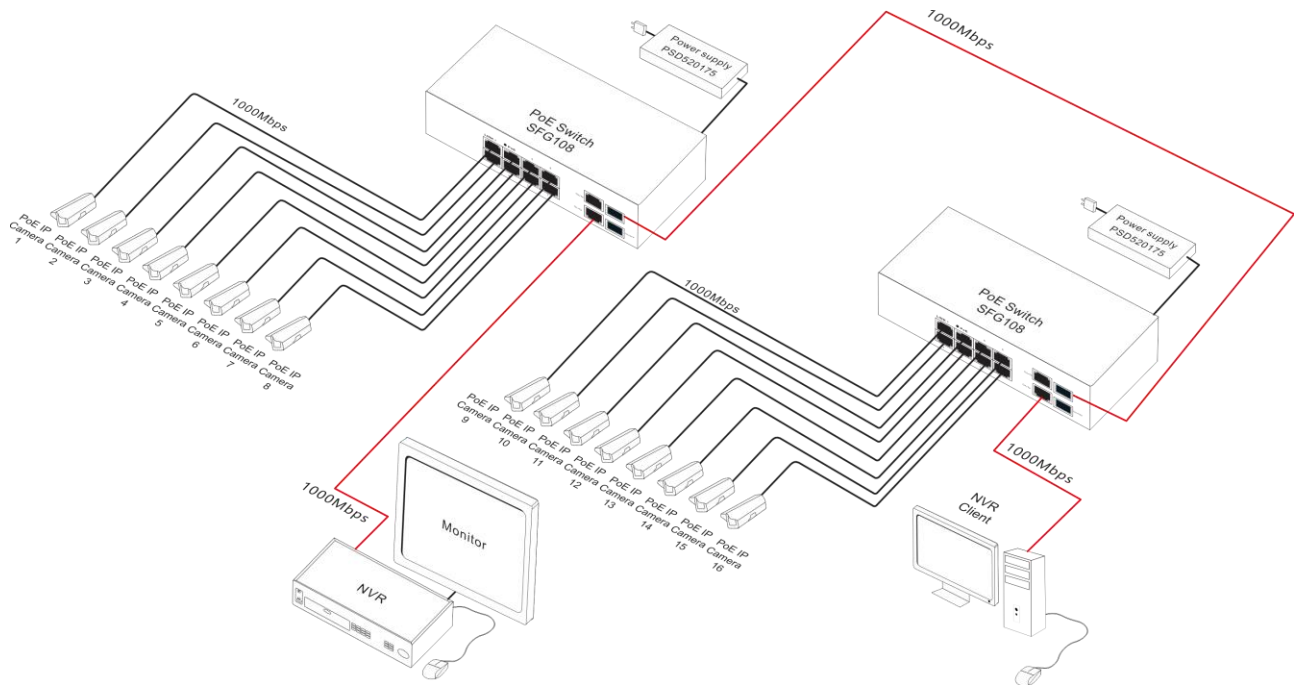



3. Operation indication (see Table 3)

Table 3. Operation indication

OPTICAL INDICATION OF THE SWITCH'S POWER SUPPLY

GREEN LED LIGHT (Power) Indication of the switch's power supply	PWR 	OFF – no power supply of the switch ON – power supply on, normal operation
---	--	---

OPTICAL INDICATION AT THE PoE PORTS (1÷8)

GREEN LED LIGHT (PoE) Indication of the PoE power supply at the RJ45 ports		OFF – no power supply at the RJ45 port (the device is not connected or not compliant with the IEEE802.3af/at standard) ON – power supply Blinking – short-circuit or output overload
YELLOW LED LIGHT (LINK) The connection status of LAN 10/100/1000 Mb/s and data transmission		OFF – no connection ON – the device is connected 10/100/1000 Mb/s Blinking – data transmission

OPTICAL INDICATION AT THE UPLINK PORT (TP/9 and TP/10)

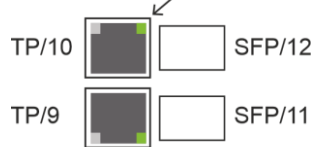
YELLOW LED LIGHT (SPEED)		OFF – connected 10 Mb/s or 100 Mb/s ON – connected 1000 Mb/s
GREEN LED LIGHT (LINK)		OFF – no connection ON – the device is connected Blinking – data transmission

OPTICAL INDICATION AT THE UPLINK PORT (SFP/11 and SFP/12)

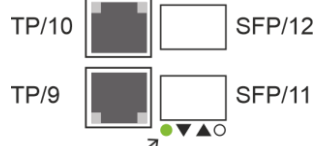
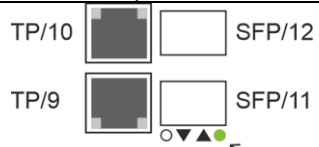
GREEN LED LIGHT (SFP/11)		OFF – no connection ON – the device is connected Blinking – data transmission
GREEN LED LIGHT (SFP/12)		OFF – no connection ON – the device is connected Blinking – data transmission



WEEE LABEL

Waste electrical and electronic equipment must not be disposed of with normal household waste. According to European Union WEEE Directive, waste electrical and electronic equipment should be disposed of separately from normal household waste.

Pulsar sp. j.

Siedlec 150,
 32-744 Łapczyca, Poland
 Tel. (+48) 14-610-19-45
 e-mail: sales@pulsar.pl
[http:// www.pulsar.pl](http://www.pulsar.pl)

