

Features:

- 6 ports switch
- 4 PoE ports 10/100/1000 Mb/s (data transfer and power supply)
- 1 port 10/100/1000 Mb/s (UP LINK, TP)
- 1 port 1000 Mb/s (UP LINK, SFP)
- 30 W for each PoE port, supports devices compliant with the IEEE802.3af/at (**PoE+**) standard
- Supports auto-learning and auto-aging of MAC addresses (2K size)
- Built-in switch mode power supply PSD520115 52 V DC/1,15 A/60 W
- Additional mounting elements
- LED indication
- warranty – 2 years from production date

Example of use.

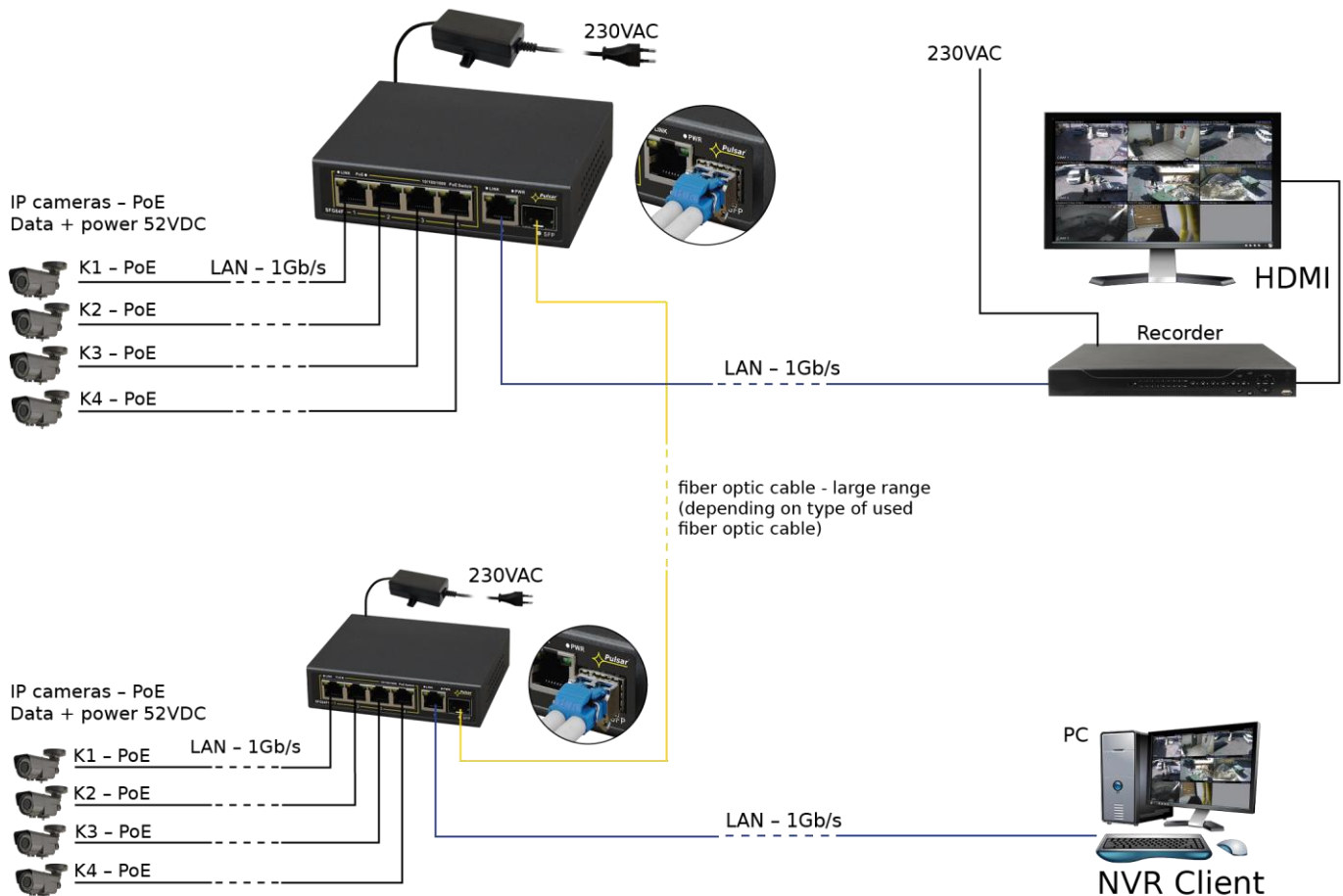

1. Technical description

1.1. General description.

SFG64F1 is a 6-ports PoE switch designed to supply IP cameras operating in IEEE 802.3af/at standard. Automatic detection of any devices powered in the PoE/PoE+ standard is enabled at the 1 – 4 ports of the switch. The UP LINK (5 and SFP) ports is used for connection of another network device via of fiber optic (shall be used GBIC SFP port). The LEDs at the front panel indicate the operation status (description in the table below).

The PoE technology ensures a network connection and reduces installation costs by eliminating the need to supply a separate power cable for each device. This method allows supplying other network devices, such as IP phone, wireless access point or router.

1.2 Block diagram.

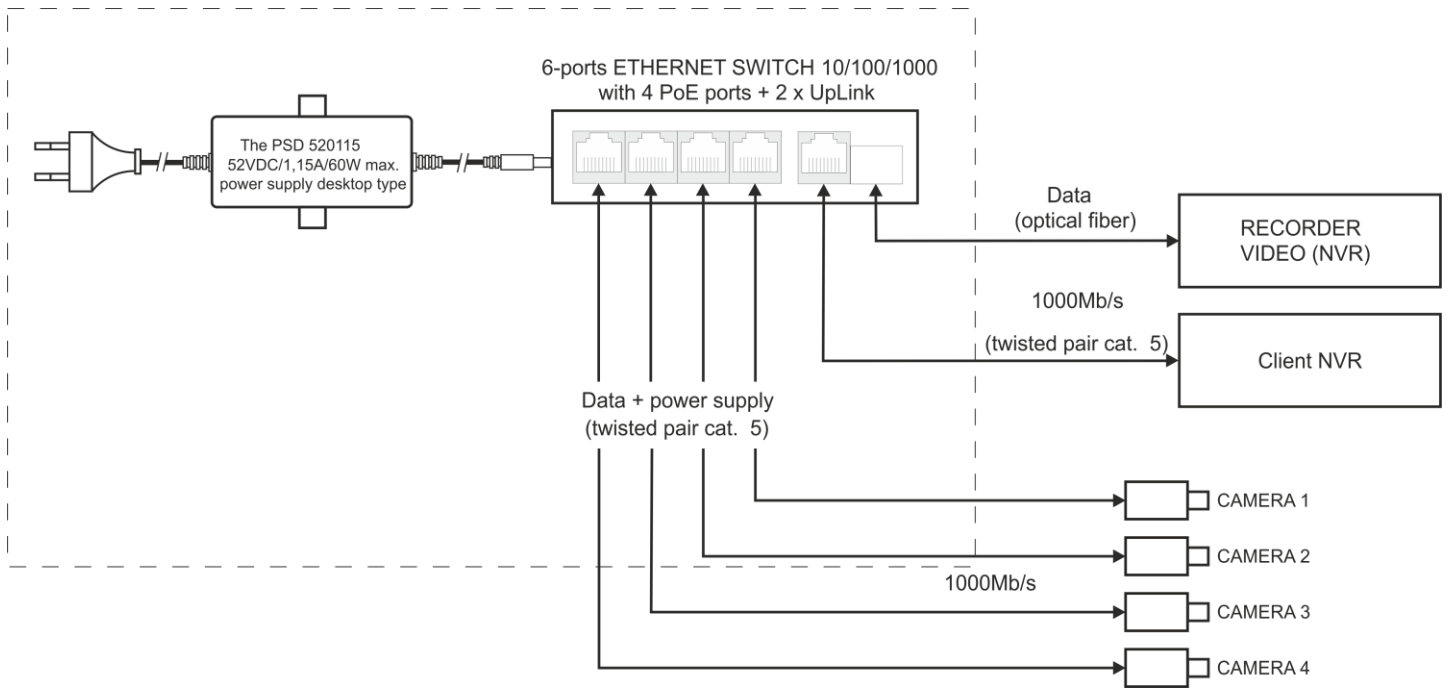

Fig. 1. Block diagram.

1.3. Description of components and connectors.

Table 1. (see Fig.2)

Element no. (Fig. 2)	Description
[1]	1 x UP LINK port (SFP)
[2]	1 x UP LINK port (TP)
[3]	4 x PoE ports (1÷4)
[4]	DC power supply socket
[5]	Additional mounting elements

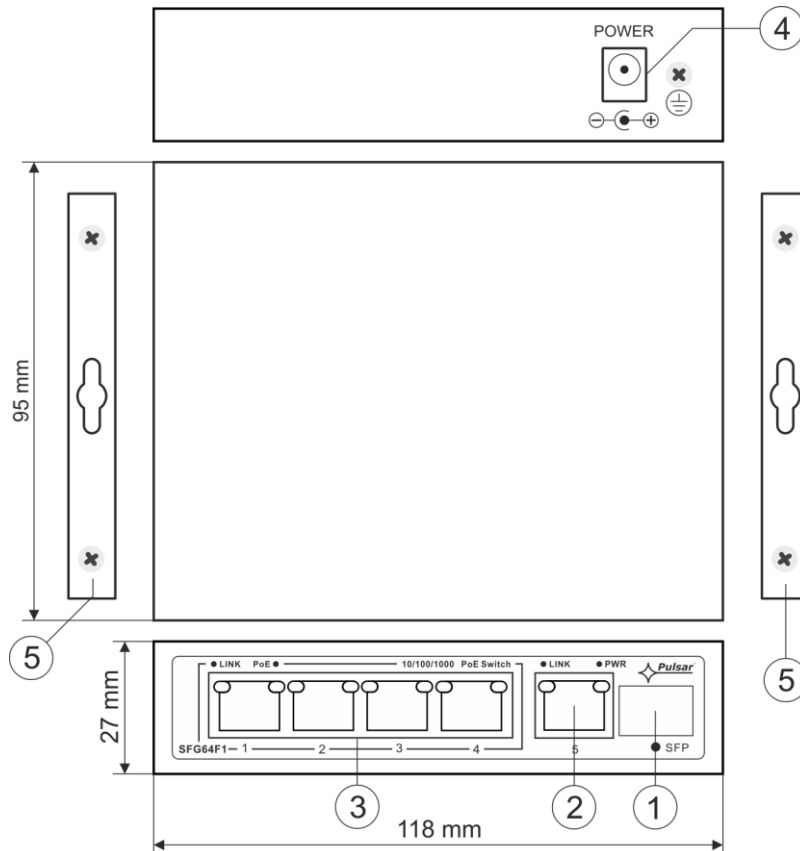

Fig. 2. The enclosure view.

1.4. Technical parameters.

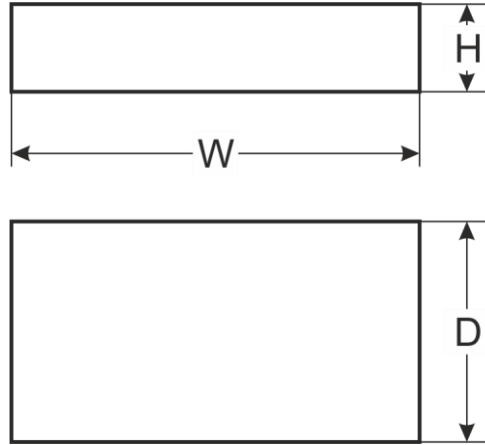

Table 2.

Ports	6 ports (4 x PoE + 2 x UP LINK) 4 ports PoE 10/100/1000 Mb/s (RJ45) 1 port 10/100/1000 Mb/s (TP) 1 port 1000 Mb/s (SFP) with connection speed auto-negotiation and MDI/MDIX Auto Cross
PoE power supply	IEEE 802.3af/at (1+4 ports), 52 V DC / 30 W at each port *
Protocols, Standards	IEEE802.3, 802.3u, 802.3x CSMA/CD, TCP/IP
Bandwidth	12 Gb/s
Transmission method	Store-and-Forward
Optical indication of operation	Switch power supply; Link/Act; PoE Status
Power supply	~100-240 V; 50/60 Hz; 1,3 A switched mode power supply PSD520115 52 V DC / 1,15 A/60 W max.
Operating conditions	Temperature: -10°C ÷ +40°C, relative humidity 20%...90%, without condensation
Dimensions	W=118, H=28, D=95 [+/- 2mm]
Additional equipment	surface mounting sheets
Net/gross weight	0,6 / 0,8 [kg]
Protection class EN 62368-1	II (second)
Storage temperatur	-20°C ÷ +60°C
Declarations	CE

* The given value of 30 W per port is the maximum value. The total power consumption should not exceed 48 W.

2. Installation

2.1. Requirements

The unit should be mounted in confined spaces, in accordance with the II environmental class, with normal relative humidity (RH=90% maximum, without condensation) and temperature from -10°C to +40°C. Ensure the free flow of air around the unit. The PSU shall work in a vertical position that guarantees sufficient convectional air-flow through ventilating holes of the enclosure.

The load balance should be done before installation Switcha. The given value of 30 W per port is the maximum value referring to a single output. The total power consumption should not exceed 48 W when all PoE ports are being used.

The increased demand for power is particularly evident in the case of cameras with heaters or infrared illuminators - when launching these features, the power consumption increases rapidly, which may adversely affect the operation of the switch. The device is designed for a continuous operation and is not equipped with a power-switch. Therefore, an appropriate overload protection in the power supply circuit should be provided. The electrical system shall be made in accordance with applicable standards and regulations.

2.2. Installation procedure

1. Connect switch to the PSD520115 52 V DC power supply unit desktop type.
2. Connect the power supply to the 230 V socket.
3. Connect the camera wires to the RJ45 connectors (PoE connectors).
4. Check the optical indication of the switch operation (see Table 3).

Connection schemes:

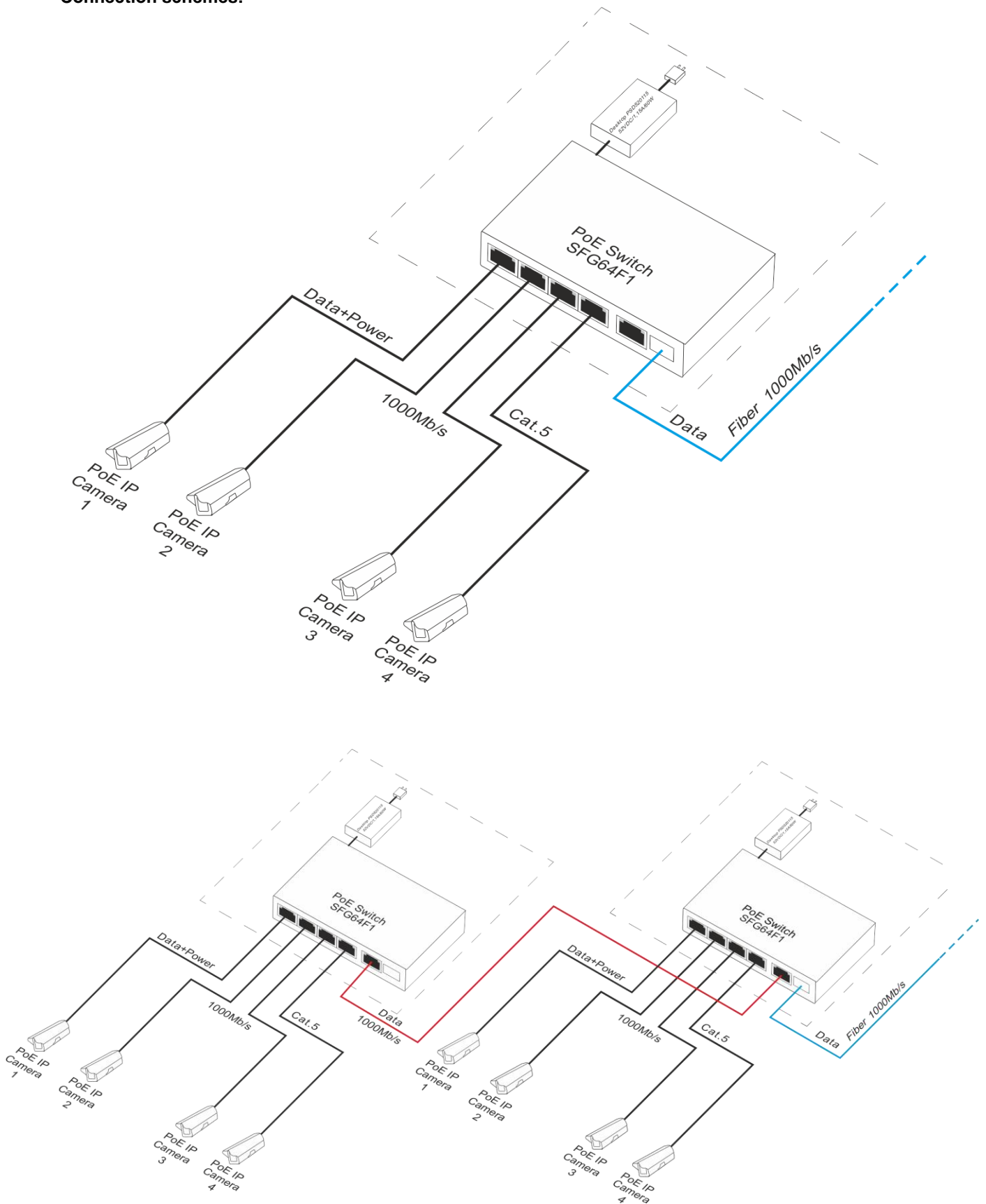



3. Operation indication.

Table 4. Operation indication



OPTICAL INDICATION OF THE SWITCH'S POWER SUPPLY

<p>GREEN LED LIGHT (Power) Indication of the switch's power supply</p>	<p>PWR ●</p>	<p>OFF – no power supply of the switch ON – power supply on, normal operation</p>
---	---------------------	---

OPTICAL INDICATION AT THE PoE PORTS (1÷4)

<p>GREEN LED LIGHT (PoE) Indication of the PoE power supply at the RJ45 ports</p>		<p>OFF – no power supply at the RJ45 port (the device is not connected or not compliant with the IEEE802.3af/at standard) ON – supply at the RJ45 port Blinking – short-circuit or output overload</p>
<p>YELLOW LED LIGHT (LINK) The connection status of LAN devices, 10/100/1000 Mb/s and data transmission</p>		<p>OFF – no connection ON – the device is connected; 10/100/1000 Mb/s Blinking – data transmission</p>

OPTICAL INDICATION AT THE UP LINK PORTS

<p>GREEN LED LIGHT</p>		<p>OFF – no connection/ the device is connected 10/100 Mb/s ON – the device is connected 1000 Mb/s</p>
<p>YELLOW LED LIGHT (LINK) The connection status of LAN devices and data transmission</p>		<p>OFF – no connection ON - the device is connected 10/100/1000 Mb/s Blinking – data transmission</p>
<p>YELLOW LED LIGHT (SFP) The connection status of LAN devices and data transmission</p>	<p>SFP ●</p>	<p>OFF – no connection ON – the device is connected Blinking – data transmission</p>



WEEE LABEL

Waste electrical and electronic equipment must not be disposed of with normal household waste. According to the European Union WEEE Directive, waste electrical and electronic equipment should be disposed of separately from normal household waste.

Pulsar sp. j.

Siedlec 150, 32-744 Łapczyca, Poland

Tel. (+48) 14-610-19-45

e-mail: sales@pulsar.pl

http:// www.pulsar.pl

