

### Features:

- Switch 6 ports  
4 PoE ports 10/100/1000 Mb/s (data transfer and power supply)  
2 ports 10/100/1000 Mb/s (UpLink)
- 30 W for each PoE port, supports devices compliant with the IEEE802.3af/at (**PoE+**) standard
- Supports auto-learning and auto-aging of MAC addresses (1K size)
- Pole mounting option (requires OZB2 adapter - **optional accessory**)
- Built-in switch mode power supply PSCL520115  
52 V DC/1,15 A/60 W max, a set includes
- Protections:
  - SCP short circuit protection
  - OLP overload protection
  - surge protection (AC input)
- LED indication
- warranty – 1 year from production date

### Example of use.

SG64H

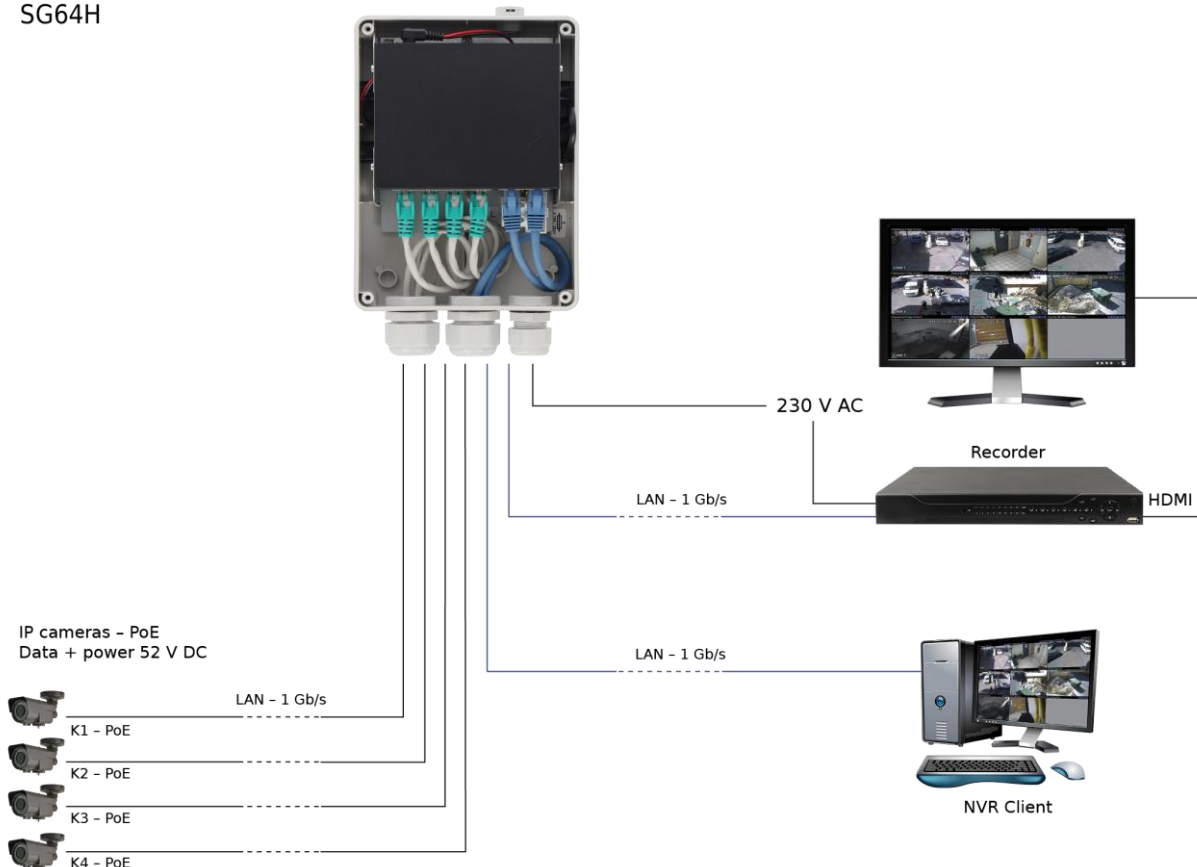

## 1. Technical description

### 1.1. General description.

SG64H is a 6-ports PoE switch designed to supply IP cameras operating in IEEE 802.3af/at standard. Automatic detection of any devices powered in the PoE/PoE+ standard is enabled at the 1 – 4 ports of the switch. The UpLink ports are used for connection of another network device via RJ45 connector. The LEDs at the front panel indicate the operation status (description in the table below).

The PoE technology ensures a network connection and reduces installation costs by eliminating the need to supply a separate power cable for each device. This method allows supplying other network devices, such as IP phone, wireless access point or router.

## 1.2 Block diagram.

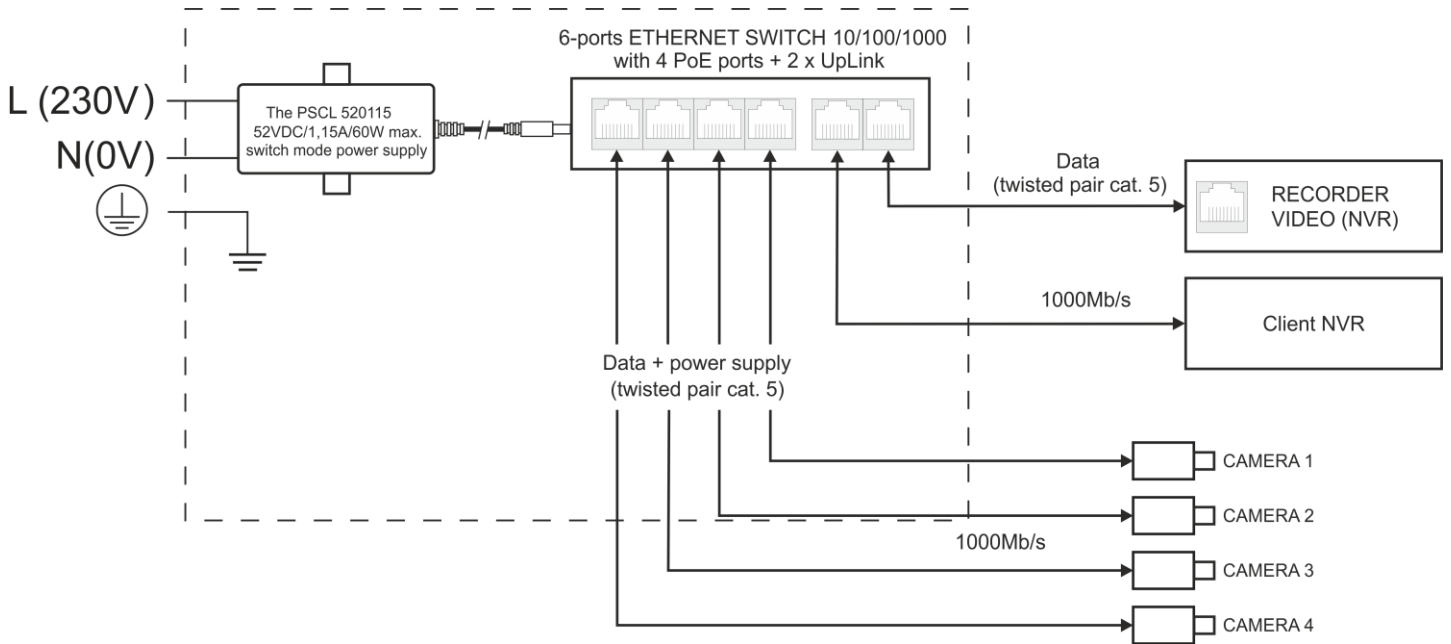

Fig. 1. Block diagram.

## 1.3. Description of components and connectors.

Table 1. (see Fig.2)

Element no. (Fig. 2)	Description
[1]	Pressure Compensator
[2]	PoE switch
[3]	Power supply connector of the PSU – L, N Protective connector
[4]	F <sub>MAINS</sub> fuse in the supply circuit (~230 V)
[5]	Cable glands

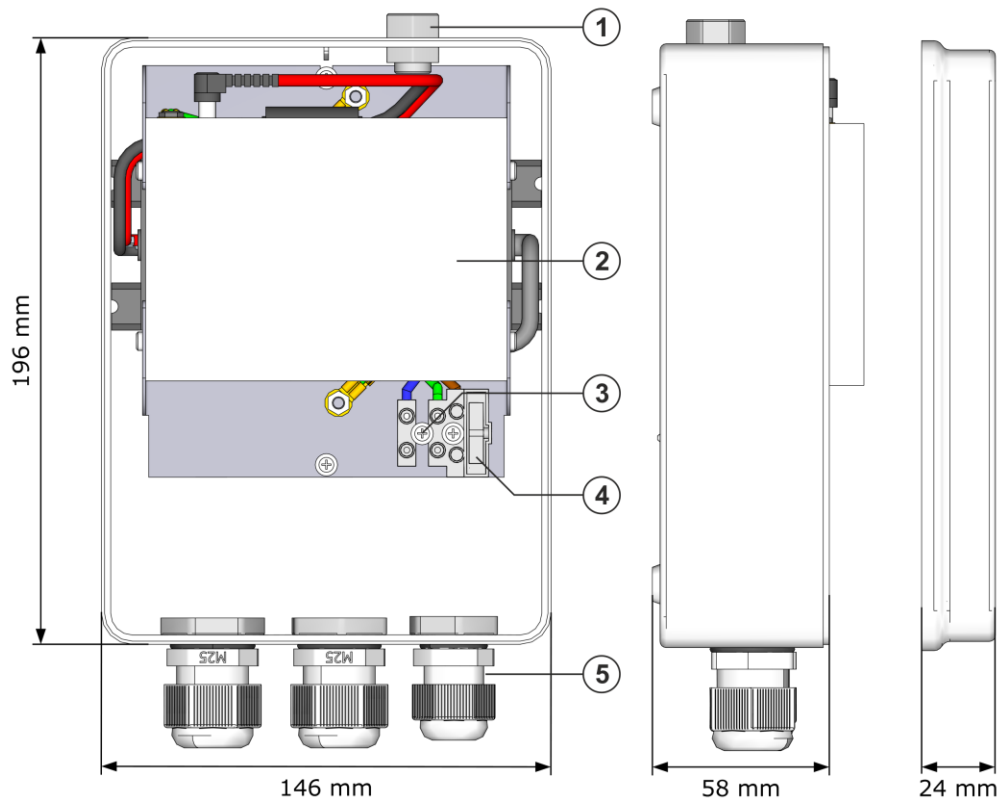

Fig. 2. The enclosure view.

Table 2. (see Fig. 3)

Element no. (Fig. 2)	Description
[1]	2 x UpLink ports
[2]	4 x PoE ports (1÷4)
[3]	DC power supply socket

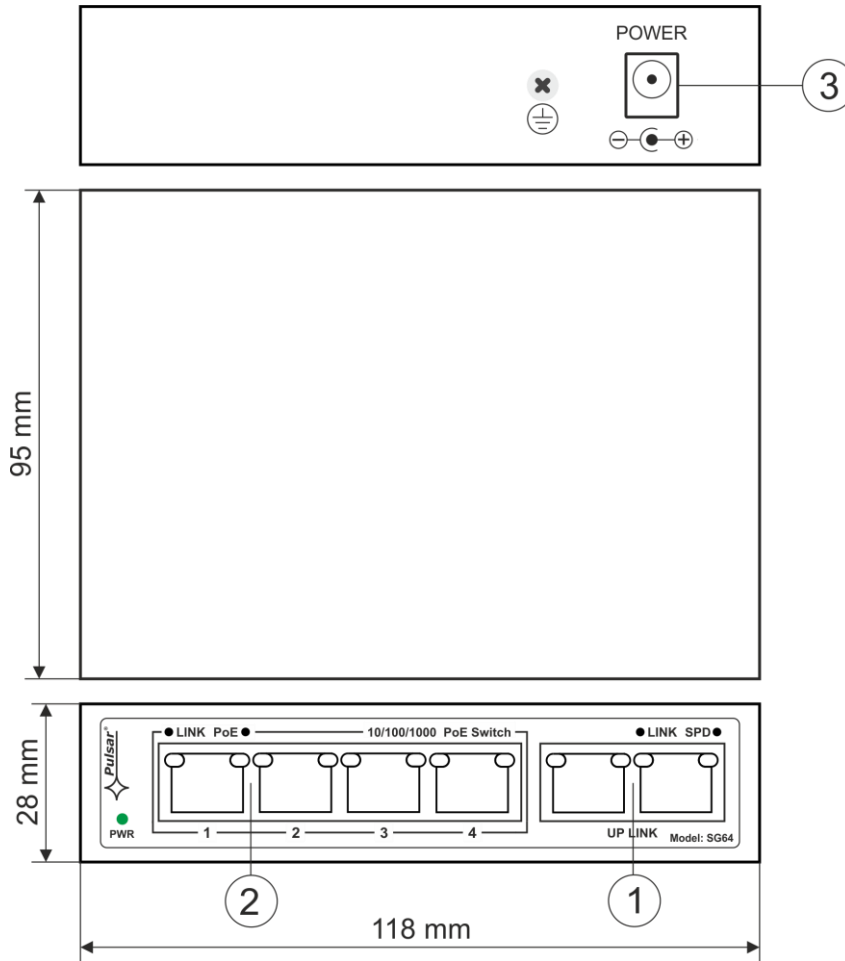
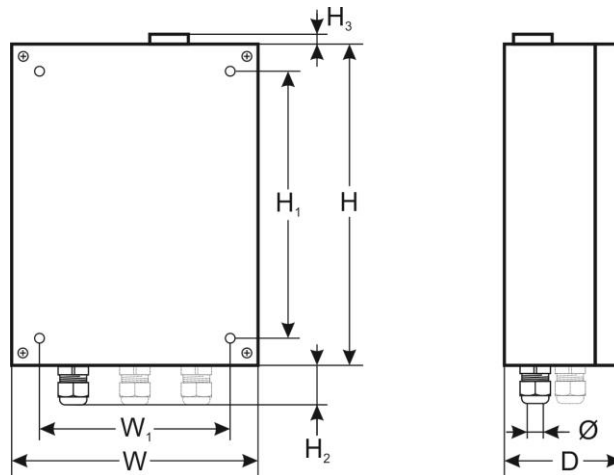

Fig. 3. The view switch'a.

1.4. Technical parameters.



**Table 3. Specifications.**

<b>Ports</b>	6 ports 10/100/1000 Mb/s (4 x PoE + 2 x UpLink) with auto negotiation of connection speed, auto MDI/MDIX crossover
<b>PoE supply</b>	IEEE 802.3af/at (1+4 ports), 52 V DC / 30 W at each port *
<b>Protocols, Standards</b>	IEEE802.3, 802.3u, 802.3x CSMA/CD, TCP/IP
<b>Capacity</b>	8,8 Gb/s
<b>Transmission method</b>	Store-and-Forward
<b>LED operation indication</b>	Switch supplying; Link/Act; PoE Status
<b>Short circuit protection (SCP)</b>	electronic, automatic recovery
<b>Overload protection (OLP)</b>	150 % – 200 % PSU power, automatically recovered
<b>Power supply</b>	~100 – 240 V; 50/60 Hz; 0,6 A power supply desktop type PSCL520115 52 V DC / 1,15 A/60 W max.
<b>Fuse F<sub>MAINS</sub></b>	T3,15A/250V
<b>External dimensions</b>	W=146, H=196, D=78 [+/- 2 mm]
<b>Mounting dimensions</b>	W <sub>1</sub> =105, H <sub>1</sub> =155 [+/- 2 mm]
<b>Height glands</b>	H <sub>2</sub> =35 mm
<b>Dimensions of pressure compensator</b>	H <sub>3</sub> =9 [mm]
<b>Number of cable glands/cable diameter</b>	2 pc. / 13 – 18 mm + 1 pc. / 10 – 14 mm
<b>Gland filling inserts</b>	3x Ø5mm (2 pc.)
<b>Enclosure</b>	ABS, light grey
<b>Net/gross weight</b>	1,3 / 1,4 [kg]
<b>Declaration</b>	CE

\* The given value of 30 W per port is the maximum value. The total power consumption should not exceed 30 W.

**Table 4. Operation safety.**

Protection class EN 62368-1	I (first)
Protection grade EN 60529	IP56
Electrical strength of insulation: - between input and output circuits of the PSU - between input circuit and protection circuit - between output circuit and protection circuit	4000 V DC min. 2500 V DC min. 500 V DC min.
Insulation resistance: - between input circuit and output or protection circuit	100 MΩ, 500 V DC

**Table 5. Operating parameters.**

Operating temperature	-25°C...+50°C
Storage temperature	-25°C...+60°C
Relative humidity	20%...90%, without condensation
Vibrations during operation	unacceptable
Impulse waves during operation	unacceptable
Direct insolation	unacceptable
Vibrations and impulse waves during transport	According to PN-83/T-42106

## 2. Installation

### 2.1. Requirements

Device is designed to be installed only by qualified installer with necessary permits and authorisations (required in installation country) to connect (interfere) with the 230 V mains supply. Device is recommended to be installed in a place protected from direct influence of atmospheric conditions and strong sunlight with temperatures from -25°C to +50°C. It is possible to mount device on a pole by using OZB2 mounting plate (not included).

The load balance should be done before installation Switcha. The given value of 30 W per port is the maximum value referring to a single output. The total power consumption should not exceed 30 W when all PoE ports are being used. The increased demand for power is particularly evident in the case of cameras with heaters or infrared illuminators - when launching these features, the power consumption increases rapidly, which may adversely affect the operation of the switch. The device is designed for a continuous operation and is not equipped with a power-switch. Therefore, an appropriate overload protection in the power supply circuit should be provided. The electrical system shall be made in accordance with applicable standards and regulations.

### 2.2. Installation procedure



**Before installation, cut off voltage in 230 V power-supply circuit. To switch power off, use an external switch, in which distance between contacts of all poles in disconnection state is not less than 3mm.**

**It is required to install in the supply circuits, in addition to power supply, circuit breaker with 6 A nominal current.**

1. Mount device and feed connection wires through glands and filler inserts. Then tighten the glands (unused ones should be blanked off).
2. Connect power cables ~230 V to L-N clips of PSU. Connect ground wire to clip marked by earth symbol (⊕). Use a three-core cable (with a yellow and green protection wire) to make connection (⊕). Lead the power cables to the relevant terminals of the power supply via an isolation conduit. Wires should be deisolated to a length of 7mm.

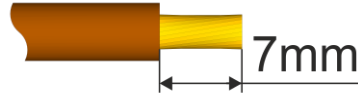

**The shock protection circuit shall be done with a particular care: the yellow and green wire coat of the power cable should be connected to the terminal marked with the grounding symbol on the PSU enclosure. Operation of the PSU without the properly made and fully operational shock protection circuit is UNACCEPTABLE! It can cause damage to the equipment or an electric shock.**

3. Switch on ~230 V supply
4. Connect the camera cables to the RJ45 (connector PoE).
5. Check the switch operation indicator (see Table 4).
6. After installing and checking proper working of the device, enclosure the housing tightly.

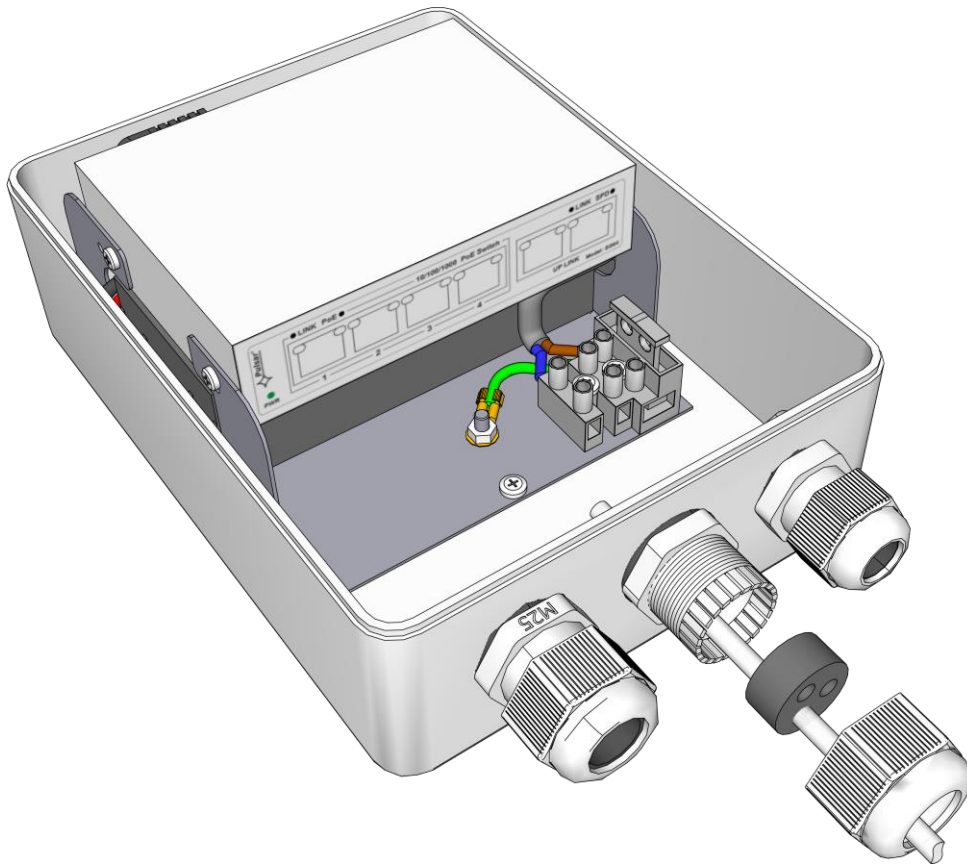



Fig.4. Example of installation



### 3. Operation indication.

Table 4. Operation indication



#### OPTICAL INDICATION OF THE SWITCH's POWER SUPPLY

<b>GREEN LED LIGHT (Power)</b> Indication of the switch's power supply	<b>PWR</b> 	<b>OFF</b> - no power supply of the switch <b>ON</b> - power supply on, normal operation
---	--	---

#### OPTICAL INDICATION AT THE PoE PORTS (1÷4)

<b>GREEN LED LIGHT (PoE)</b> Indication of the PoE power supply at the RJ45 ports		<b>OFF</b> - no power supply at the RJ45 port (the device is not connected or not compliant with the IEEE802.3af/at standard) <b>ON</b> - supply at the RJ45 port <b>Blinking</b> – short-circuit or output overload
<b>YELLOW LED LIGHT (LINK)</b> The connection status of LAN devices, 10/100/1000 Mb/s and data transmission		<b>OFF</b> - no connection <b>ON</b> - the device is connected; 10/100/1000 Mb/s <b>Blinking</b> – data transmission

#### OPTICAL INDICATION AT THE UP LINK PORTS

<b>GREEN LED LIGHT</b>		<b>OFF</b> - no connection/ the device is connected; 10/100 Mb/s <b>ON</b> - the device is connected; 1000 Mb/s
<b>YELLOW LED LIGHT (LINK)</b> The connection status of LAN devices, 10/100/1000 Mb/s and data transmission		<b>OFF</b> - no data transmission <b>ON</b> - the device is connected; 10/100/1000 Mb/s <b>Blinking</b> - data transmission



#### WEEE LABEL

Waste electrical and electronic equipment must not be disposed of with normal household waste. According to European Union WEEE Directive, waste electrical and electronic equipment should be disposed of separately from normal household waste.

<b>Pulsar sp. j.</b> Siedlec 150, 32-744 Łapczyca, Poland Tel. (+48) 14-610-19-45 e-mail: <a href="mailto:sales@pulsar.pl">sales@pulsar.pl</a> <a href="http://www.pulsar.pl">http:// www.pulsar.pl</a>	Facebook 	LinkedIn 	YouTube 	Pulsar.pl 
--	--	--	---	---