

Features:

- Switch 6 ports
 - 4 ports PoE 10/100/1000 Mb/s (data transfer and power supply)
 - 2 ports 10/100/1000 Mb/s (UP LINK)
- 60 W for each PoE port, supports devices complaint with the IEEE802.3af/at/bt standard
- Supports auto-learning and auto-aging of MAC addresses (8K size)
- LED indication
- Additional assembly elements
- Warranty – 2 years

Example of use.

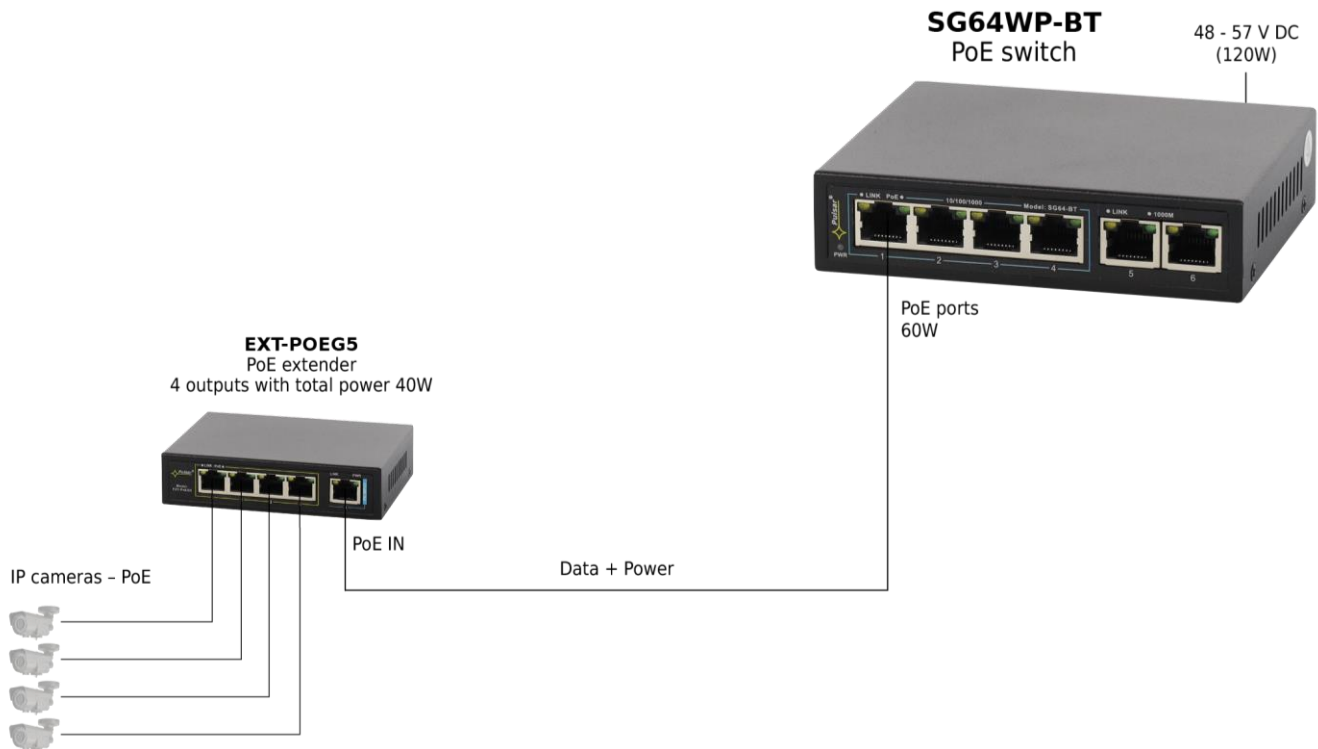

1. Technical description

1.1. General description.

SG64WP-BT is a 6-ports PoE switch designed to supply IP devices operating in IEEE 802.3af/at/bt standard, e.g. cameras IP, video intercoms, Access control etc.

Automatic detection of any devices powered in the PoE standard is enabled at the 1 – 4 ports of the switch. The UP LINK ports is used for connection of another network device via RJ45 connector. The LEDs at the front panel indicate the operation status (description in the table below).

The PoE technology ensures a network connection and reduces installation costs by eliminating the need to supply a separate power cable for each device. This method allows supplying other network devices, such as IP phone, wireless access point or router.

1.2 Block diagram.

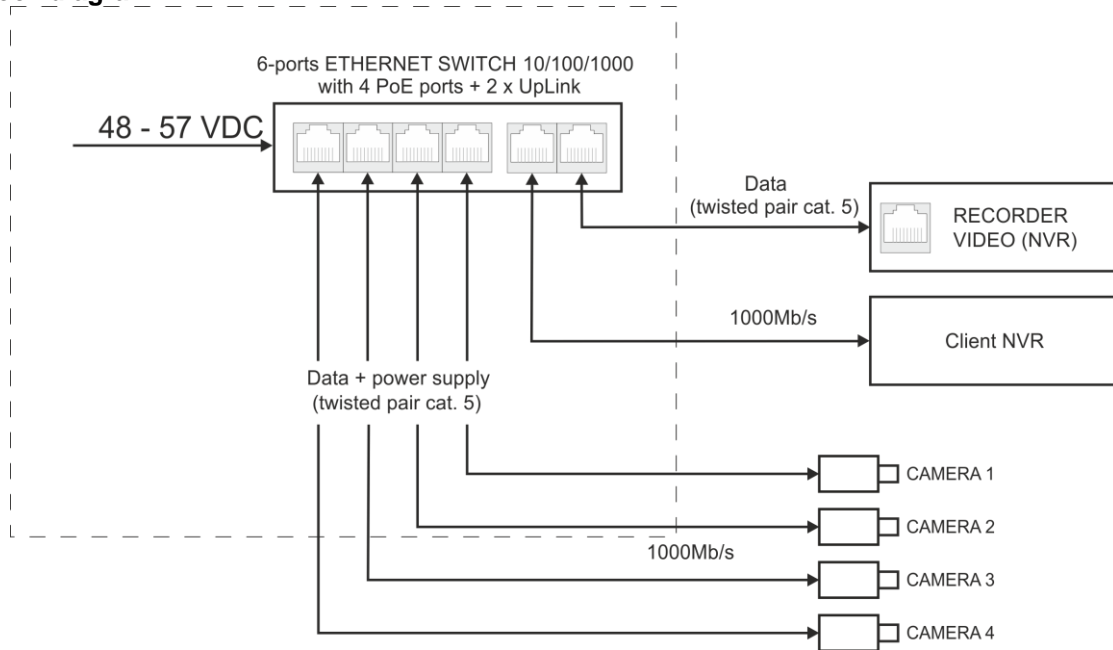

Fig. 1. Block diagram.

1.3. Description of components and connectors.

Table 1. (see Fig.2)

Element no. (Fig. 2)	Description
[1]	2 x UP LINK port
[2]	4 x PoE port (1÷4)
[3]	Power Socket of the DC
[4]	Additional mounting elements

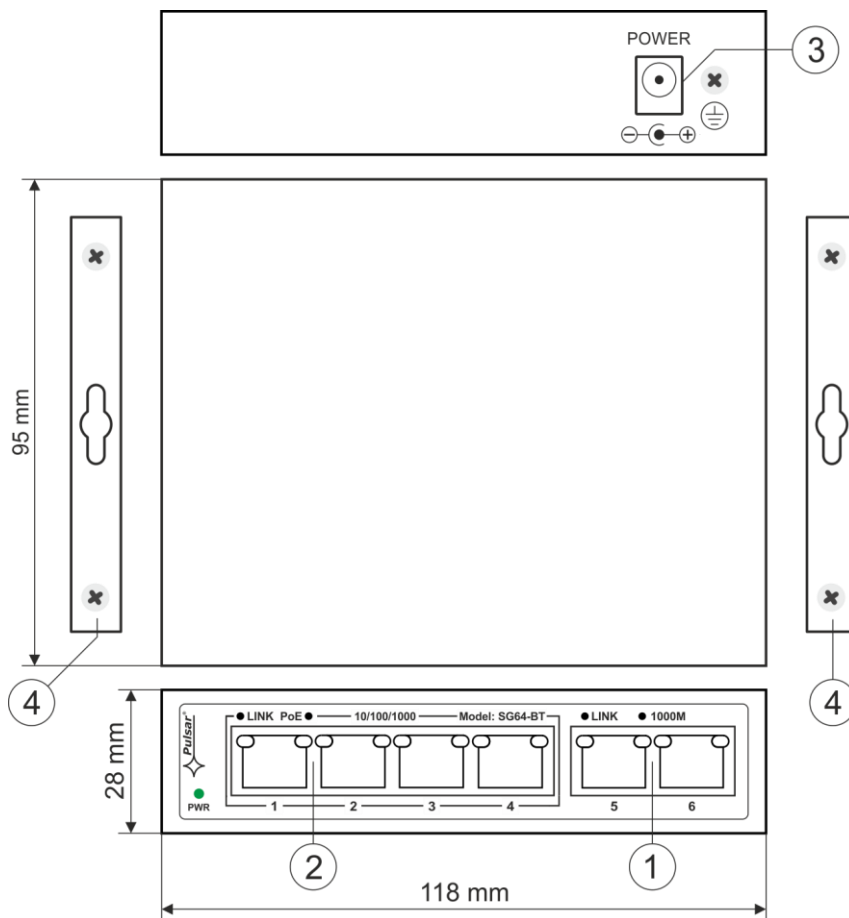

Fig. 2. View of the switch.

1.4. Technical parameters.

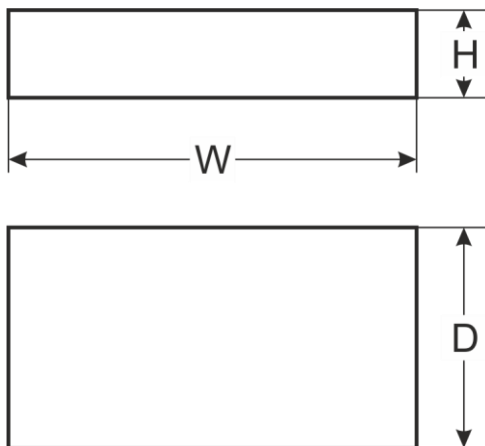

Table 2.

Ports	6 10/100/1000 Mb/s ports (4 x PoE + 2 x UP LINK) with connection speed auto-negotiation and MDI/MDIX Auto Cross
PoE power supply	IEEE 802.3af/at/bt (1÷4 ports), 52 V DC / 60 W at each port *
Protocols, Standards	IEEE802.3, 802.3u, 802.3x CSMA/CD, TCP/IP
Bandwidth	16,6 Gb/s
Transmission method	Store-and-Forward
Optical indication of operation	Switch power supply; Link/Act; PoE Status
Power supply	48 – 57 V DC; 2,5 A max
Operating conditions	Temperature -10°C ÷ 40°C, relative humidity 5% - 90%, no condensation
Dimensions	W=118, H=28, D=95 [+/- 2mm]
Additional equipment	plate to be fixed surface
Net/gross weight	0,6 / 0,8 [kg]
Protection class EN 62368-1	II (second)
Storage temperature	-20°C ÷ 60°C
Declarations	CE

* The given value of 60 W per port is the maximum value. The total power consumption should not exceed 120 W.

2. Installation

2.1. Requirements

Unit should be mounted in confined spaces, in accordance, with normal relative humidity (RH=90% maximum, without condensing) and temperature from -10°C to +40°C. Ensure the free flow of air around the unit. The device shall work in a vertical position that guarantees sufficient convectional air-flow through ventilating holes of the enclosure.

The load balance should be done before installation Switcha. The given value of 60 W per port is the maximum value referring to a single output. The total power consumption should not exceed 120 W and depends on the current efficiency of the PSU, taking account of the power intake for the own needs of the device. The increased demand for power is particularly evident in the case of cameras with heaters or infrared illuminators - when launching these features, the power consumption increases rapidly, which may adversely affect the operation of the switch. The device is designed for a continuous operation and is not equipped with a power-switch. Therefore, an appropriate overload protection in the power supply circuit should be provided. The electrical system shall be made in accordance with applicable standards and regulations.

2.2. Installation procedure

1. Connect switch to power supply unit.
2. Connect the power supply to the 230 V socket.
3. Connect the camera wires to the RJ45 connectors (PoE connectors).
4. Check the optical indication of switch operation (see Table 3).

Connection schemes:

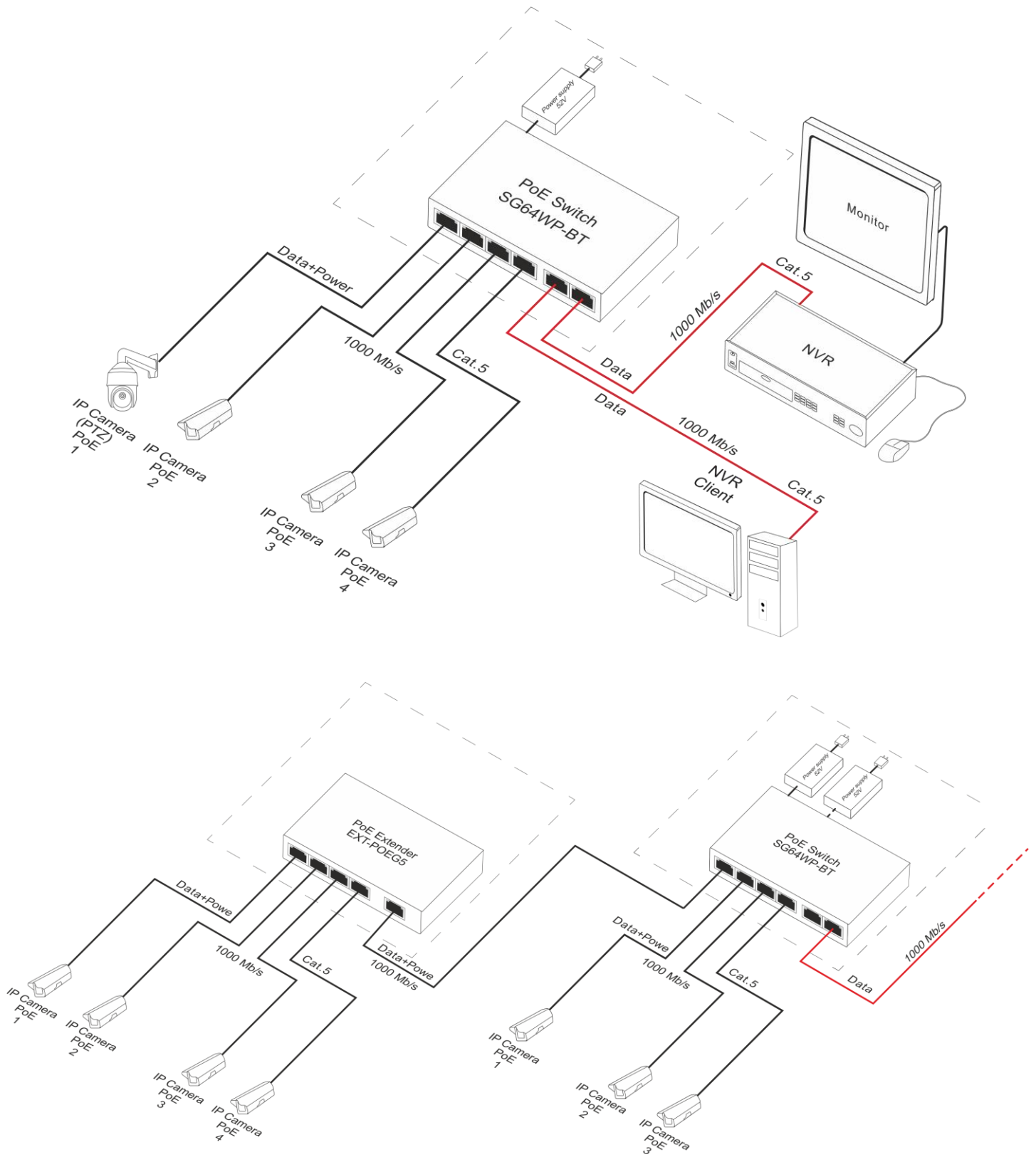



3. Operation indication.

Table 3. Operation indication



OPTICAL INDICATION OF THE SWITCH'S POWER SUPPLY

GREEN LED LIGHT (Power) Indication of the switch's power supply	PWR 	OFF – no power supply of the switch ON – power supply on, normal operation
---	--	---

OPTICAL INDICATION AT THE PoE PORTS (1÷4)

GREEN LED LIGHT (PoE) Indication of the PoE power supply at the RJ45 ports		OFF – no power supply at the RJ45 port (the device is not connected or not compliant with the IEEE802.3af/at/bt standard) ON – supply at the RJ45 port Blinking – short-circuit or output overload
YELLOW LED LIGHT (LINK) The connection status of LAN devices, 10/100/1000 Mb/s and data transmission		OFF – no connection ON – the device is connected; 10/100/1000 Mb/s Blinking – data transmission

OPTICAL INDICATION AT THE UP LINK PORT

GREEN LED LIGHT		OFF – no connection/ the device is connected; 10/100 Mb/s ON – the device is connected 1000 Mb/s
YELLOW LED LIGHT (LINK) The connection status of LAN devices, 10/100/1000 Mb/s and data transmission		OFF – no data transmission ON – the device is connected 10/100/1000 Mb/s Blinking – data transmission



WEEE LABEL

Waste electrical and electronic equipment must not be disposed of with normal household waste. According to the European Union WEEE Directive, waste electrical and electronic equipment should be disposed of separately from normal household waste.

Pulsar sp. j.

Siedlec 150, 32-744 Łapczyca, Poland

Tel. (+48) 14-610-19-45

e-mail: sales@pulsar.pl

http:// www.pulsar.pl

