



# USER MANUAL

EN

Edition: 1 from 24.01.2022

Supersedes the edition:

## SWR-300

v1.0

**Buffer power supply system for PoE switches and recorder 12VDC/54VDC/4x17Ah/300W**



**Features:**

- Supply voltage ~200 - 240 V
- High efficiency (87%)
- 54 V supply for PoE switches
- 12 V supply for recorder
- Battery charging and maintenance control
- Deep discharge battery protection
- Battery charging current: 0,5 A/1 A/2 A, jumper selectable
- Metal enclosure – colour white RAL9003
- Removable universal mounting plate
- Optical indication
- Protections:
  - SCP short circuit protection
  - OLP overload protection
  - OVP overvoltage protection
  - surge protection
  - antisabotage protection: unwanted enclosure opening
  - OHP overheat protection
  - battery protection against reverse connection
- Forced cooling - built-in fan
- Warranty – 2 years from production date

**TABLE OF CONTENTS:****1. Technical description.****1.1. General description****1.2. Block diagram****1.3. Description of PSU components and connectors****1.4. Specifications****2. Installation.****2.1. Requirements****2.2. Installation procedure****3. Operating status indication.****3.1. Optical indication****4. Maintenance****1. Technical description.****1.1. General description.**

Buffer power supply system for PoE switches and recorder, SWR-300 is designed for uninterrupted power supply of PoE switches with 52 V DC and recorder supplied with 12 V DC. It is designed on basis of switch mode power supply module and high-energy-efficiency DC/DC converter placed in metal enclosure (colour RAL 9003). In enclosure is space for four 17Ah/12 V (SLA) batteries and is equipped with microswitch signalling door opening. Device is equipped with removable universal mounting plates, which allows to mount PoE switches with dimensions up to 245x150x50 (WxHxD) [mm]. For example Pulsar's models: **S64, SG64, SFG64, SFG64F1, S108, SG108, SF108**), and recorder with dimensions up to 380x380x48 (WxHxD) [mm].

Device can operate in one of two configurations:

1. Output power \* 300 W
2. Output power \* 270 W + 0,5 A battery charging process
3. Output power \* 240 W + 1 A battery charging process
4. Output power \* 210 W + 2 A battery charging process

\* Total power of PoE devices and NVR, maximum power of NVR is 60 W.

**1.2. Block diagram (Fig.1).**

Fig.1. Block diagram of PSU.

1.3. Description of PSU components and connectors.

Table 1. View of PSU (see Fig. 3).

Element no.	Description
[1]	PSU module
[2]	Mounting holes
[3]	Screws for locking mounting plate
[4]	Cable bushing
[5]	<b>TAMPER</b> ; microswitch of antisabotage protection (NC)
[6]	Switch power cable terminated with a DC 2.1/5.5 plug
[7]	Power cable for recorder terminated with DC 2.1/5.5 plug
[8]	BAT +, BAT - battery output + BAT red, - BAT black
[9]	Selection jumper for charging current • J1=  J2=  J3=  I <sub>bat</sub> =0,5 A • J1=  J2=  J3=  I <sub>bat</sub> =1 A • J1=  J2=  J3=  I <sub>bat</sub> =2 A Description:  jumper installed,  jumper removed

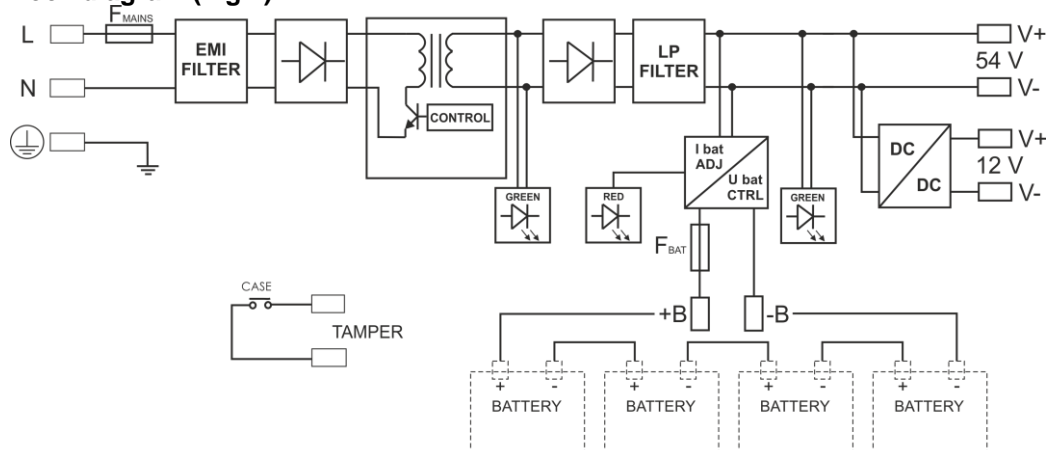
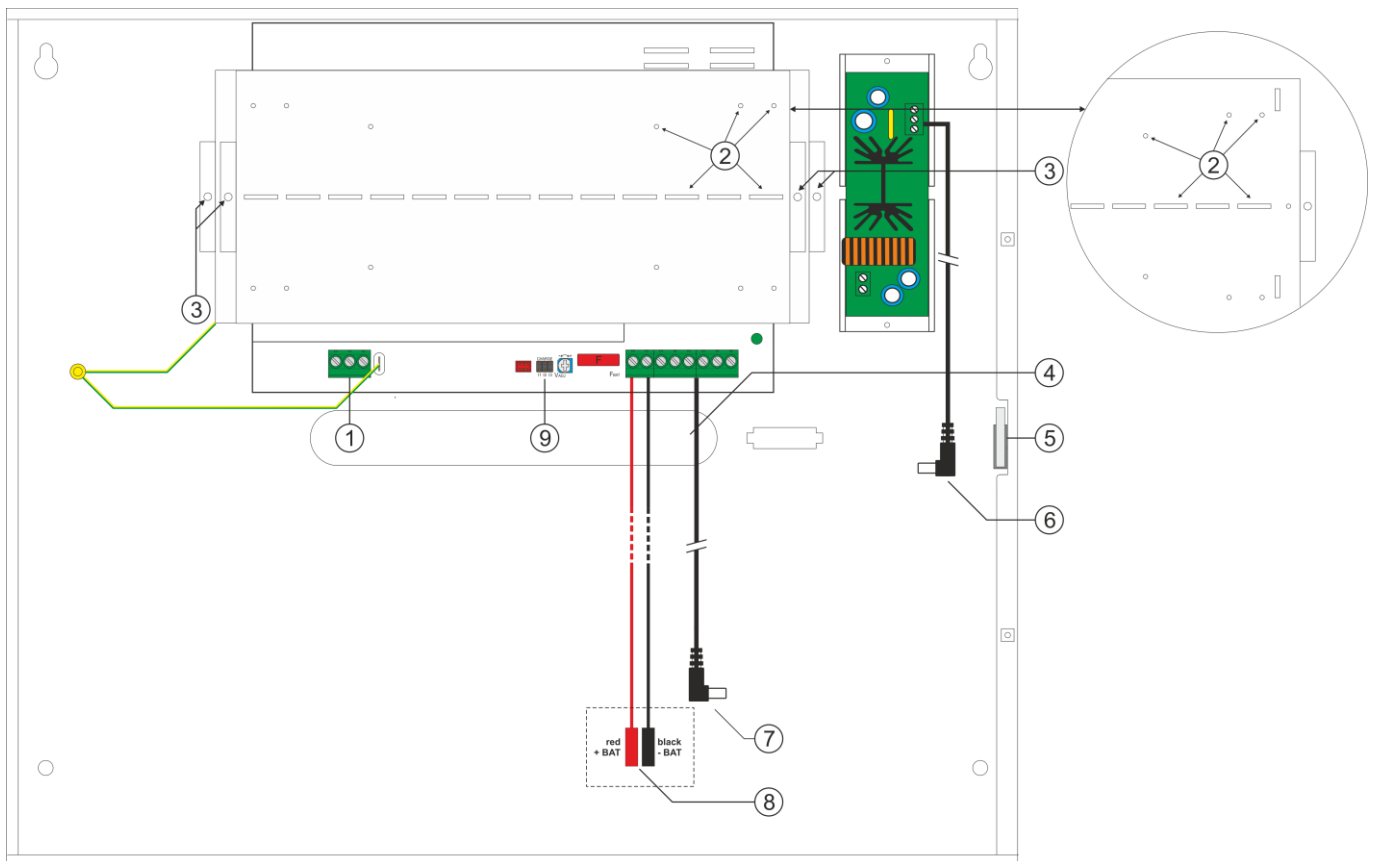
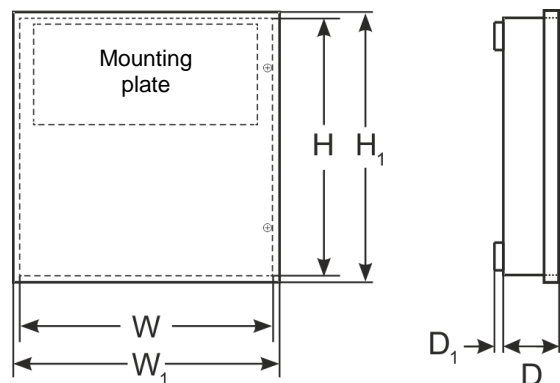

Fig.3. View of device.

1.4. Specifications:

- electrical parameters (tab. 3)
- mechanical parameters (tab. 4)
- operation safety (tab. 5)
- operating parameters (tab. 6)



**Table 2. Specifications.**

<b>Power supply</b>	~ 200 – 240 V; 1,5 A; 50/60 Hz	
<b>Inrush current</b>	60 A	
<b>Efficiency</b>	87%	
<b>PoE supply</b>	54 V DC; 300 W	
<b>Recorder power supply</b>	12 V DC; 5 A; 60 W	
<b>Ripple voltage</b>	150 mV p-p max.	
<b>Battery charging voltage</b>	44-54 V DC	
<b>Battery charging current</b>	0,5 A / 1 A / 2 A jumper selectable	
<b>Short circuit protection (SCP)</b>	electronic, automatic recovery	
<b>Overload protection (OLP)</b>	105 – 150% of power supply, automatic recovery	
<b>Surge protection</b>	varistors	
<b>Current consumption by PSU during battery-assisted operation</b>	about 30 mA	
<b>LED optical indication output</b>	LED AC - presence of AC voltage LED DC - presence of DC voltage in the output of the PSU LED CHARGE - battery charging process	
<b>Connectors</b>	Power input: $\Phi$ 0,63-2,50 (AWG 22-10) PoE power supply output: DC plug 2.1/5.5 Recorder power supply output: DC plug 2,1/5,5 BAT output: battery wires $\Phi$ 6 (M6-1,5) 45cm,	
<b>Dimensions</b>	W=330, H=380, D+D <sub>1</sub> =173+8 [+/- 2mm] W <sub>1</sub> =335, H <sub>1</sub> =385 [+/- 2mm]	
<b>Enclosure</b>	Steel sheet, DC01 1,0mm colour RAL 9003	
<b>Installation space (WxHxD):</b>	Batteries 4x7 Ah	Batteries 4x17 Ah
- switch	245x150x50	245x150x50
- recorder	380x380x48	380x280x48
<b>Closing</b>	Cheese head screw x 2 (at the front, lock assembly possible)	
<b>Notes</b>	Enclosure does not adjoin assembly surface so that cables can be led.	
<b>Additional equipment</b>	Mounting screws (x4)	
<b>Net/gross weight</b>	7,8 / 8,6 [kg]	
<b>Declaration</b>	CE	

**Table 3. Operation safety.**

Protection class EN 62368-1	I (first)
Degree of Protection EN 60529	IP20
Electrical strength of insulation: - between input input and output circuits of PSU - between input circuit and protection circuit - between output circuit and protection circuit	2500 V AC min. 1500 V AC min. 500 V AC min.
Insulation resistance: - between input circuit and output or protection circuit	100 M $\Omega$ , 500 V DC

**Table 4. Operating parameters.**

Operating temperature	-10°C...+40°C
Storage temperature	-20°C...+60°C
Relative humidity	20%...90%, without condensation
Vibrations during operation	unacceptable
Impulse waves during operation	unacceptable
Direct insulation	unacceptable
Vibrations and impulse waves during transport	According to PN-83/T-42106

## 2. Installation.

### 2.1 Requirements.

Device is to be mounted by a qualified installer, holding relevant permits and licenses (applicable and required for a given country) for ~230 V in and low-voltage installations. Unit should be mounted in confined spaces, in accordance, with normal relative humidity (RH=90% maximum, without condensing) and temperature from -10°C to +40°C.

As power supply is designed for a continuous operation and is not equipped with a power-switch, therefore, an appropriate overload protection in power supply circuit should be provided. Moreover, user should be informed how to disconnect power supply unit from mains supply (most frequently through separating and assigning an appropriate fuse in the fuse-box).

## 2.2 Installation procedure.



### CAUTION!

Before installation, cut off voltage in 230 V power-supply circuit. To switch power off, use an external switch, in which distance between contacts of all poles in disconnection state is not less than 3mm.

It is required to install in the supply circuits, in addition to power supply, circuit breaker with 6 A nominal current.

1. Mount the device in a selected location and connect the wires.
2. Remove mounting plate by unscrewing screws, then release plate from hooks (slide up and slightly pull).
3. Connect the power cables (~230 V) to L-N clips of the PSU. Connect the ground wire to the clip marked by the earth symbol  $\oplus$ . Use a three-core cable (with a yellow and green protection wire) to make the connection. Lead the cables to the appropriate clips through the insulating bushing of the PSU.



Shock protection circuit shall be done with a particular care: yellow and green wire coat of power cable should be connected to terminal marked with the grounding symbol on PSU enclosure. Operation of PSU without the properly made and fully operational shock protection circuit is UNACCEPTABLE! It can cause damage to equipment or an electric shock.

4. Connect battery in correct polarity.
5. Make the selection is done with use of the IBAT jumpers (see: tab.1)
6. Screw switch to bottom mounting plate.
7. Connect switch using cable labelled „52 V DC” terminated with DC 2.1/5.5 plug.
8. Place recorder on upper mounting plate with screws or provided straps.
9. Connect recorder using cable labelled „12 V DC” terminated with DC 2.1/5.5 plug.

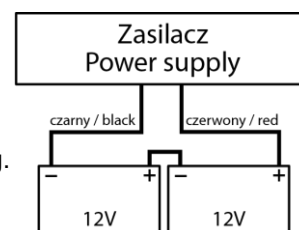

**CAUTION: Wrong connection of power cables may result in damage to equipment! Ensure that power supply parameters are suitable for each device!**

10. Mount inside enclosure.
11. Switch on 230 V supply.
12. After installing and checking proper working, the enclosure can be closed.

## 3. Operating status indication.

The power supply unit features LED status indication

### 3.1 Optical indication.

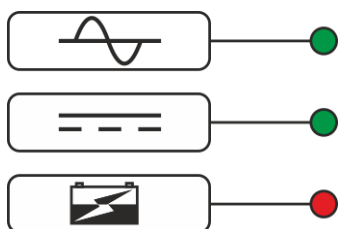

#### Green LED AC:

- on –PSU is supplied with 230 V
- off - no 230 V power, battery-assisted operation

#### Green LED DC:

- on - presence voltage in output of PSU
- off - no voltage in the output of the PSU

#### Red LED CHARGE:

- off – no battery charging
- on - battery charging process

Moreover, PSU is equipped with LED indicating presence of voltage at PSU output, located on PCB of PSU module.

### 3. Maintenance.

Any and all maintenance operations may be performed following the disconnection of the PSU module from the power supply network. The PSU does not require performing any specific maintenance measures, however, in the case of significant dust rate, its interior is recommended to be cleaned with compressed air. In the case of a fuse replacement, use a replacement of the same parameters.



#### WEEE MARK

According to the EU WEE Directive – It is required not to dispose of electric or electronic waste as unsorted municipal waste and to collect such WEEE separately.



**CAUTION!** The power supply module unit is adapted for a sealed lead-acid battery (SLA). After the operation period it must not be disposed of but recycled according to the applicable law.

#### **Pulsar sp. j.**

Siedlec 150, 32-744 Łapczyca, Poland  
Tel. (+48) 14-610-19-40, Fax. (+48) 14-610-19-50  
e-mail: [biuro@pulsar.pl](mailto:biuro@pulsar.pl), [sales@pulsar.pl](mailto:sales@pulsar.pl)  
http:// [www.pulsar.pl](http://www.pulsar.pl), [www.zasilacze.pl](http://www.zasilacze.pl)