

CODE: **AWO804Z** v.1.1/IV
 NAME: **TOM4Z Surface-mounted residential telecommunication enclosures**

EN**

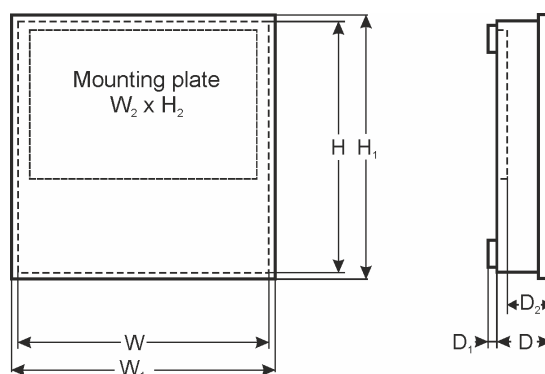

APPLICATION

The surface-mounted residential telecommunication enclosures need to be installed in public buildings and collective residential buildings.

The surface-mounted residential telecommunication enclosures should provide the possibility of a simple (without the need to replace the entire cable infrastructure) connection of telecommunications companies to the telecommunication installation of the building on the principle of equal access.



PRODUCT DESCRIPTION

The surface-mounted residential telecommunication enclosures allow the integration of the elements of computer network, telephone network, television network (TV, SAT), fiber-optic network and other telecommunication installations. This is done by easily removable adapter with a space for "keystone" type sockets (installation of RJ45 and "F" connectors), additional holes for the "F" connectors, holes for the SC / APC (single and double) fiber optic connectors and for mounting of 45x45mm hardware applies to.

This can be done with easily removable adapter with a space for the "keystone"-type sockets (mounting of the RJ45 and „F” connectors), additional holes for the „F” connectors and the SC/APC fiber optic connectors (both single and double).

MAIN FEATURES

1. Surface mounted construction.
2. Removable door (convenient installation of wiring and other equipment).
3. Mounting plate (easy and quick installation of additional equipment).
4. The set includes adapter for mounting the RJ45 Keystone socket, F connectors and SC/APC fiber optic connectors.
5. Several embossed openings for entering the cables.
6. Enclosure locked with a key.

TECHNICAL PARAMETERS

External dimensions of the enclosure:	W=245, H=295, D+D1=80 + 8 [+/-2mm]
External dimensions of the front panel:	W1=250, H1=300 [+/-2mm]
Mounting plate dimensions:	W2=230, H2=155 [+/-2mm]
Working depth:	D2=70 [+/-2mm]
Possibility of mounting:	<ul style="list-style-type: none"> - keystone connectors (eg.RJ45, BNC) – 9 pcs. - dual „F” sockets (F-F connector) – 8 pcs. - simplex fiber optic adapter - SC – 2 pcs. - duplex fiber optic adapter - APC – 1 pcs. - standard size 45 × 45mm - 1 pcs.
Net/gross weight:	2,64kg / 2,75kg [+/-0,1kg]
Materials:	electrolytic galvanized sheet DC01, 3µm zinc coating, corrosion protection: polyester paint, industrial use, color RAL9003 (white)
Destination:	indoor
Closing:	key lock
Warranty:	3 year from the production date