

Code: **RK664-G v.1.0 / I**  
Name: **6U / 19" RACK cabinet, wall mounted, vandal-resistant, grey, 600x400**

EN

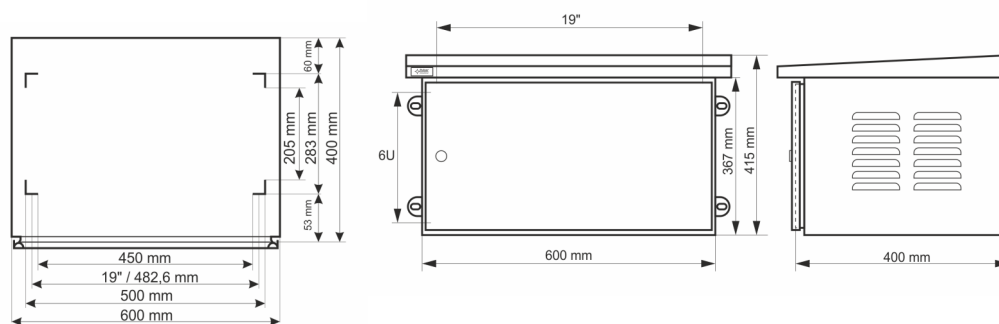

## DESTINATION

RACK 19" cabinet enables integrating CCTV, AC, I&HAS, RTV, LAN, or other systems in small companies or households. It is intended for devices manufactured in enclosures of 19" standard. Due to RACK cabinets, devices are aesthetically mounted and protected against mechanical damage.

## TECHNICAL DATA

<b>Mounting dimensions:</b>	19" x 6U
<b>Dimensions:</b>	600 x 367 x 400 [mm, +/-2] Additional protective inclined top panel with height of 48 mm
<b>Material:</b>	cold-rolled steel SPCC, 2mm, 1.2mm, RAL7035 (grey), metallic RACK mounting rails - 2mm enclosure - 1.2mm mounting brackets - 2mm
<b>Static load:</b>	80 [kg]
<b>Closing:</b>	locked (2 keys included)
<b>Destination:</b>	indoor
<b>Protection grade EN60529:</b>	IP 20
<b>Weight:</b>	17.3 / 18.9 [kg]
<b>Type Cabinets:</b>	wall mounted fully assembled - vandal-resistant
<b>Notes:</b>	adjustable distance between front and rear RACK rails ventilation holes in the top panel (2 x 105x105mm - mounting dimensions) cable glands in the bottom panel - 4 x ø35mm
<b>Warranty:</b>	2 years
<b>Declaration:</b>	CE

