

CODE: **USH-1** v.1.0/II
 NAME: **Pole mounting bracket for hermetic enclosures adjustable up to 270 mm**

EN

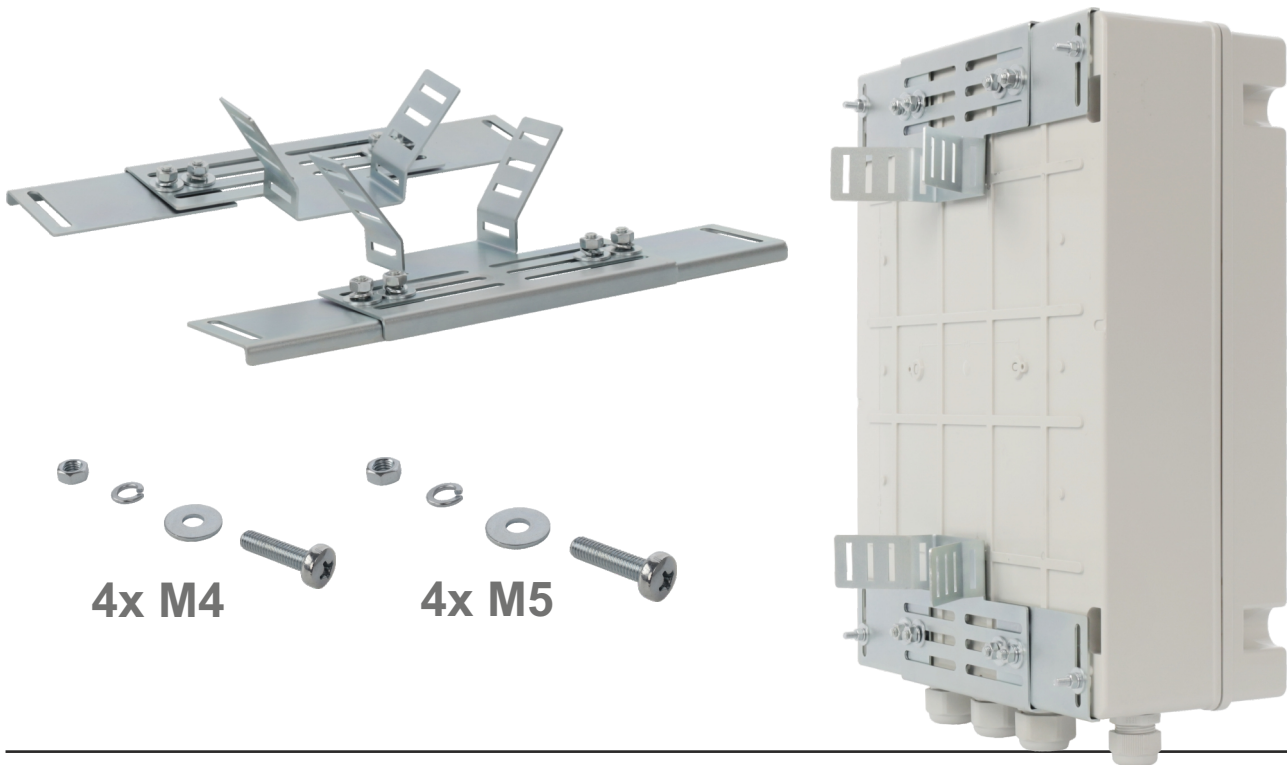

Features:

- Adjustable spacing (20 mm - 270 mm)
- Weather-resistant

DESTINATION

The bracket is designed for mounting hermetic enclosures on poles and masts. The bracket ensures the stability of the enclosure, and is adapted to the weight of the enclosure as well as the weather conditions (1,5 mm sheet metal, electro-galvanised). It is dedicated to solutions for:

- security systems - mounting of surveillance cameras and alarm systems on poles
- telecommunications - mounting of telecommunication cabinets on poles and masts
- industrial automation - pole mounting of control cabinets and automation equipment

Note: for mounting the bracket, steel ties with appropriate load capacity are required.

TECHNICAL DATA

Dimensions:	L=290, W=58, H=60 [+/- 2 mm]
Net/gross weight:	0,72 / 1,00 [kg]
Material:	steel DC01+ZE, thickness: 1,5 mm, electro-galvanised
Destination:	outdoor / indoor
Notes:	- Set of 4 M4 and M5 screws included (screw, spring washer, washer, nut) - M6 nut mounting kit (washer, spring washer, nut)
Warranty:	2 years

Configuration:

Hole spacing 181 – 270 mm

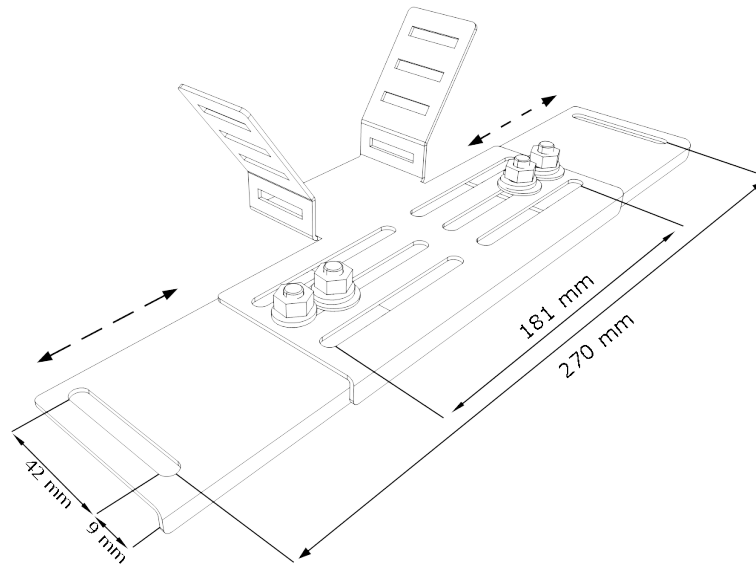

Hole spacing 100 – 205 mm

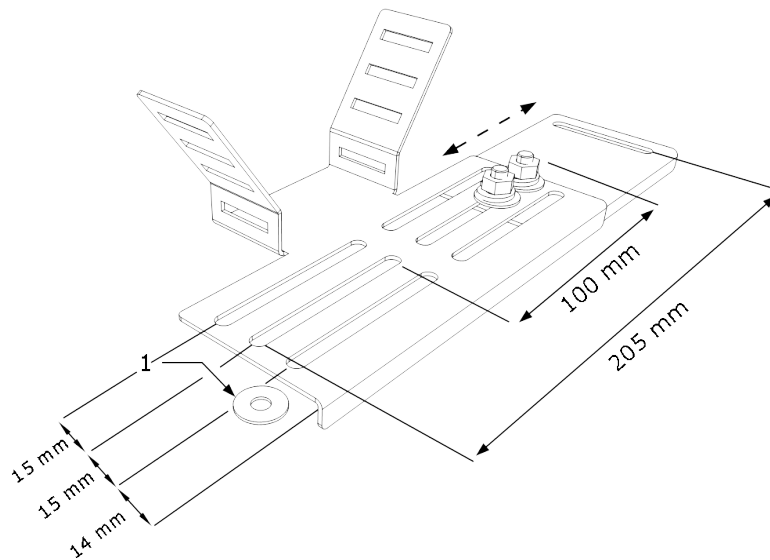

Hole spacing 20 – 140 mm

