

Codice: **RWA954-B** v.1.0/1

Nome: **Armadio RACK 9U / 19"**, montato a parete, pronto per il montaggio, nero, **540x400**

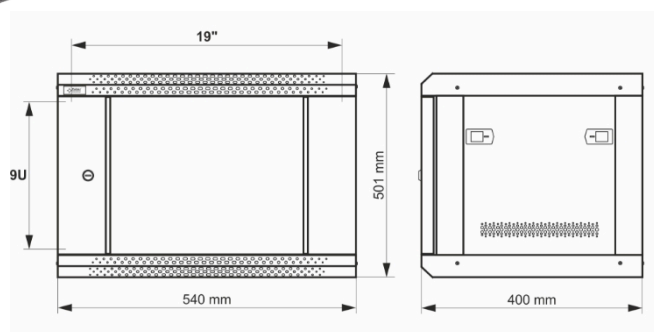

IT

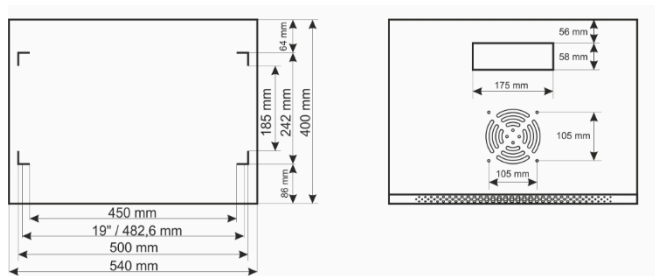

## DESTINAZIONE

Gli armadi RACK 19" consentono di integrare sistemi CCTV, AC, I&HAS, RTV, LAN o altri sistemi in piccole aziende o abitazioni. Sono destinati a dispositivi prodotti in involucri standard da 19". Grazie agli armadi RACK, i dispositivi sono montati in modo esteticamente gradevole e protetti da danni meccanici.

## DATI TECNICI:

<b>Dimensioni di montaggio:</b>	19" x 9U
<b>Dimensioni:</b>	540 x 501 x 400 [mm, +/-2]
<b>Materiale:</b>	acciaio laminato a freddo SPCC, 0,6 mm, 1 mm, RAL9004 (nero), metallico Guide di montaggio RACK - 1,0 mm pannello superiore e inferiore - 0,6 mm profilo di costruzione - 0,6 mm anta frontale - 0,6 mm / 4 mm vetro temperato pannelli laterali - 0,6 mm pannello posteriore - 0,6 mm
<b>Carico statico:</b>	30 [kg]
<b>Chiusura:</b>	porta frontale - serratura (RAZ-G1, stesso codice) pannello laterale - Click
<b>Destinazione:</b>	interni
<b>Grado di protezione EN60529:</b>	IP 20
<b>Peso:</b>	9,1 / 10,5 [kg]
<b>Tipo di armadi:</b>	a parete, pronti per il montaggio
<b>Note:</b>	distanza regolabile tra le guide RACK anteriori e posteriori foro di ventilazione nel pannello superiore (1 x 105x105 mm - dimensioni di installazione) canaline per cavi nel pannello superiore e inferiore (175x58 mm) anta intercambiabile - destra o sinistra
<b>Garanzia:</b>	2 anni
<b>Dichiarazione:</b>	CE



This document has been automatically translated. The translation may contain errors or inaccuracies. In case of doubt, please refer to the original version of document or contact us.